

Submersible Pump in Discharge Tube

## Amacan P

60 Hz

### Type Series Booklet



## **Legal information/Copyright**

Type Series Booklet Amacan P

All rights reserved. The contents provided herein must neither be distributed, copied, reproduced, edited or processed for any other purpose, nor otherwise transmitted, published or made available to a third party without the manufacturer's express written consent.

Subject to technical modification without prior notice.

© KSB Aktiengesellschaft, Frankenthal 04.07.2013

## Contents

<b>Water Applications: Water Transport .....</b>	<b>4</b>
Submersible Pump in Discharge Tube .....	4
Amacan P .....	4
Main applications .....	4
Fluids handled .....	4
Operating data .....	4
Designation .....	4
Design details .....	4
Materials .....	5
Coating and preservation .....	5
Product benefits .....	5
Acceptance tests / warranties .....	5
Design and selection information .....	5
Overview of product features / selection tables .....	6
Table of fluids handled .....	6
Overview of product features .....	8
Related documents .....	9
Data to be indicated in the purchase order .....	10
Material combinations .....	11
Selection chart .....	12
Amacan P, n = 1750 / 1160 / 875 / 700 / 585 / 500 rpm .....	12
Characteristic curves .....	13
n = 1750 rpm .....	13
n = 1160 rpm <sup>1</sup> .....	14
n = 875 rpm .....	19
n = 700 rpm .....	27
n = 585 rpm .....	30
n = 500 rpm .....	32
Dimensions .....	35
UAG motors (500-270 to 600-350) [inch] .....	35
UTG/XTG motors (700-470 to 1600-1060) [inch] .....	37
UAG motors (500-270 to 600-350) [mm] .....	40
UTG/XTG motors (700-470 to 1600-1060) [mm] .....	42
Types of installation .....	45
Scope of supply .....	46
Accessories .....	47
Flow-straightening vane and intake chamber .....	47
Support rope and turnbuckle in the discharge tube .....	49
Discharge tube cover with cable gland .....	50
General assembly drawings .....	52

## Water Applications: Water Transport

### Submersible Pump in Discharge Tube

## Amacan P



### Main applications

- Irrigation and drainage pumping stations
- Stormwater pumping stations
- Raw and clean water pumps in waterworks and waste water treatment plants
- Cooling water pumps in power stations and in industry
- Industrial water supply
- Water pollution and flood control
- Aquaculture

### Fluids handled

- Waste water
- Sludge
- Surface water
- Stormwater
- Waste water
- Seawater
- Brackish water

### Operating data

Operating properties

Characteristic	Value	
Flow rate	Q	Up to 70,000 US gpm [4500 l/s]
Head	H	Up to 40 ft [12 m]
Motor rating	P <sub>2</sub>	Up to 725 hp [550 kW]
Temperature of fluid pumped	t	Up to 104 °F [40 °C]

### Designation

Example: Amacan PA4 800-540 / 100 8UTG1

Key to the designation

Code	Description
Amacan	Type series
P	Impeller type, e.g. P = propeller
A	Pressure class
	A
	B
4	Number of vanes
800	Nominal diameter of the discharge tube [mm]
540	Nominal impeller diameter [mm]
100	Motor size
8	Number of motor poles
	4 4-pole
	6 6-pole
	8 8-pole
	10 10-pole
	12 12-pole
	14 14-pole
UT	Motor version (⇒ Page 8)
	UA Without explosion protection, standard for Amacan P 500-270 ... 600-350
	UT Without explosion protection, standard for Amacan P 700-470 ... 1600-1060
	XT Explosion-proof to NEC 500
G1	Material variant (⇒ Page 11)
	G1 Gray cast iron, standard material variant
	G3 Gray cast iron with Zn anodes, shaft made of A 276 type 431 stainless steel

### Design details

#### Design

- Fully floodable submersible pump in discharge tube (submersible motor pump)
- Not self-priming
- Close-coupled design
- Single-stage
- Vertical installation

#### Drive

- Three-phase asynchronous squirrel-cage motor

Version with explosion protection to NEC 500: Explosion-proof for Class I, Division 1, Groups C and D, T3, hazardous (classified) locations.

#### Shaft seal

- Two bi-directional mechanical seals in tandem arrangement, with liquid reservoir
- Leakage chamber

#### Impeller type

- Axial propeller in ECB design

#### Bearings

- Grease-packed rolling element bearings

## Materials

Overview of materials

Description	Material
Pump bowl	Gray cast iron A48 Class 30 B
Motor housing	Gray cast iron A48 Class 40 B
Shaft	Stainless steel A 276 type 420 (G1) or A 276 type 431 (G3)
Impeller	Duplex stainless steel
Casing wear ring	Stainless steel
Screws, bolts and nuts	Stainless steel

## Coating and preservation

### Paint

- **Surface treatment:** SA 2 1/2 (SIS 055900) AN 1865
- **Primer:** primer coat on unfinished casting
- **Top coat:** environmentally friendly KSB standard coating (RAL 5002)

### Special coating

- Available on request (extra charge and a longer delivery period apply).

## Product benefits

- Easy to install as pump's own weight ensures self-centering seating in the discharge tube, and an O-ring seals it. Quick to install or remove without any additional anchoring or anti-rotation elements.
- Slim motor minimizes discharge tube flow losses.
- High reliability provided by bearing temperature monitoring, vibration sensor, thermal motor protection, leakage sensors in the motor and connection space, and leakage monitoring of the mechanical seal system.
- Low-vibration hydraulic system; inlet ribs and optimized bellmouth for vortex-free inflow.
- Absolutely water-tight resin-sealed cable entries prevent any water from entering the motor – even in the event of a damaged cable.

## Acceptance tests / warranties

### Functional test

- Every pump undergoes functional testing to KSB standard ZN 56535.
- Operating data is guaranteed to DIN EN ISO 9906/2/2B or Hydraulic Institute Level B.

### Acceptance tests

- Acceptance tests to ISO/DIN or a comparable standard are available against a surcharge.

### Warranties

- Quality is assured by means of an audited and certified quality assurance system to DIN EN ISO 9001.

## Design and selection information

### Information for pump selection

The guaranteed point of submersible pumps in discharge tubes is measured at a head of 1.65 ft [0.5 m] above the motor (DIN 1184). The documented characteristic curves refer to this data. This must be taken into account when calculating system losses. The indicated heads and performance data apply to pumped fluids with a density of  $\rho = 7.48 \text{ lbs/ft}^3$  [ $1 \text{ kg/dm}^3$ ] and a kinematic viscosity  $\nu$  of up to  $20 \text{ mm}^2/\text{s}$ .

The pump input power must be matched to the density of the fluid handled:

$$P_{2\text{req.}} = \rho_{\text{fluid}} [\text{kg/dm}^3] \times P_{2\text{docu}}$$

The operating point with the largest pump input power is decisive for the operating range of the motor. To compensate the unavoidable tolerances of the characteristic curves of system, pump and motor we recommend selecting a motor size which provides sufficient power reserves.

Recommended minimum reserves<sup>1)</sup>

Required pump input power		Motor power reserve	
[hp]	[kW]	Mains operation	With frequency inverter
< 40	< 30	10 %	15 %
> 40	> 30	5 %	10 %

### Intake chamber

Determine the minimum water level  $t_{1\text{min}}$  (diagram in general arrangement drawing):

The minimum water level  $t_{1\text{min}}$  is the water level required in the pump's suction chamber to ensure the following:

- The hydraulic system (propeller) is sufficiently submerged (shown in diagram depending on pump size).
- The pump does not draw in air-entraining vortices (shown in diagram depending on flow rate).
- The hydraulic system is free from cavitation (check against the  $\text{NPSH}_{\text{required}}$  value in the technical literature. The following conditions must be met:
  - $\text{NPSH}_{\text{available}} > \text{NPSH}_{\text{required}} + \text{safety allowance}$
  - $\text{NPSH}_{\text{available}} = 10.0 + (t_1 - t_3 - h_r/2)$
  - Safety allowance:  
up to  $Q_{\text{opt}} \Rightarrow 1.65 \text{ ft}$  [0.5 m]  
larger than  $Q_{\text{opt}} \Rightarrow 3.3 \text{ ft}$  [1.0 m]

### Head (H)

The total pump head is composed as follows:

$$H = H_{\text{geo}} + \Delta H_v$$

$H_{\text{geo}}$  (static head)

- Without discharge elbow – Difference between suction-side water level and overflow edge
- With discharge elbow – Difference between suction-side and discharge-side water level

$\Delta H_v$  (losses in the system)

- Starting 1.65 ft [0.5 m] downstream of the pump: e.g. pipe friction, elbow, swing check valve, etc.

### Losses by inlet, riser and elbow

Losses are caused by the inlet, riser and elbow (or free discharge).

<sup>1)</sup> If larger reserves are stipulated by local regulations or are required to compensate for uncertain factors in system calculations, these larger reserves must be provided.

- Losses in the riser up to the indicated reference level (1.65 ft [0.5 m] above the motor) are taken into account in the documented characteristic curves.
- Inlet and elbow losses are system losses and must be taken into account for selection.
- For information on structural requirements, pump installation and pump sump design please refer to the KSB know-how brochure "Planning Information: Amacan Submersible Pumps in Discharge Tubes" 0118.55.

## Overview of product features / selection tables

### Table of fluids handled

The table below for your guidance is based on KSB's long-standing experience. The data are standard values and are not to be considered as generally binding recommendations. More detailed advice is available from our specialist department in Halle. Make use of our laboratory's expertise when selecting materials.

Selection aid for material variants and fluid temperature per fluid

Fluid handled <sup>2)</sup>	Max. permissible fluid temperature		Material variant	Casing wear ring with a groove for flushing <sup>3)</sup>	Screen	Comments, further recommendations
	[°F]	[°C]				
<b>Waste water</b>						
▪ Industrial, corrosive, non-abrasive, slightly acidic; pH value ≥ 6	104	40	G1	○	✓	2-component high solid epoxy top coat (RAL 5002) 9.84 mil [250 µm] required
▪ Industrial, corrosive, non-abrasive, with lacquer/paint/varnish suspensions	104	40	G1	○	-	Lacquer/paint/varnish suspension = free of solvents
▪ Industrial, corrosive, non-abrasive fluids containing feces	104	40	G1	✓	✓	-
▪ Industrial, corrosive, non-abrasive fluids not containing feces	104	40	G1	○	✓	-
▪ Treated municipal waste water	104	40	G1	○	✓	-
<b>Suspended solids, water/sand mixture</b>	104	40	G1	✓	-	Up to 200 mg/l
<b>Sludge</b>	104	40	G1	✓	-	Up to 2 % dry solids content
<b>Water, seawater and brackish water</b>	77 <sup>4)</sup>	25 <sup>4)</sup>	G3	○	-	Use of anodes <sup>5)</sup> and 2-component high solid epoxy top coat (RAL 5002) 9.84 mil [250 µm] required
<b>Water, cooling water</b>	104	40	G1	○	-	-
<b>Water, surface water</b>						
▪ River water	104	40	G1	✓	✓	-
▪ No details specified	104	40	G1	✓	✓	-
▪ Lake water, fresh water	104	40	G1	○	✓	-
▪ Lake water, dam water	104	40	G1	○	-	-
<b>Water, stormwater</b>						
▪ With strainer	104	40	G1	○	-	-
▪ Without strainer	104	40	G1	✓	✓	-
<b>Water, raw water</b>	104	40	G1	○	-	-
<b>Water, contaminated water</b>						

2) Fluids to be pumped which are not listed in this table usually require higher-grade materials. Contact KSB.

3) Using a casing wear ring with a groove for flushing will reduce the efficiency by 2 % to 3 %.

4) For t > 77 °F [25 °C] contact KSB (stainless steel variant).

5) Efficiency reduced by 2 % to 3 %; anode to be checked every 6 to 12 months

Fluid handled <sup>2)</sup>	Max. permissible fluid temperature		Material variant	Casing wear ring with a groove for flushing <sup>3)</sup>	Screen	Comments, further recommendations
	[°F]	[°C]				
▪ Slightly contaminated water	104	40	G1	○	-	-
▪ Mixed water, with strainer	104	40	G1	○	-	-
▪ Mixed water, without strainer	104	40	G1	✓	✓	-
▪ Mixed water containing feces	104	40	G1	✓	✓	-
▪ Mixed water not containing feces	104	40	G1	✓	✓	-
<b>Water, clean water</b>	104	40	G1	○	-	-

Key to the symbols

Symbol	Description
✓	Required
○	Optional
-	Not required

Opening size of bar screens



Size	Required bar spacing	
	[inch]	[mm]
500-270	1 <sup>3</sup> / <sub>16</sub>	30
600-350	1 <sup>3</sup> / <sub>16</sub>	30
700-470	1 <sup>9</sup> / <sub>16</sub>	40
800-540	2 <sup>3</sup> / <sub>8</sub>	60
900-540	2 <sup>3</sup> / <sub>8</sub>	60
1000-700	3 <sup>1</sup> / <sub>8</sub>	80
1200-870	3 <sup>1</sup> / <sub>8</sub>	80
1500-1060	3 <sup>1</sup> / <sub>8</sub>	80
1600-1060	3 <sup>1</sup> / <sub>8</sub>	80

<sup>2)</sup> Fluids to be pumped which are not listed in this table usually require higher-grade materials. Contact KSB.

<sup>3)</sup> Using a casing wear ring with a groove for flushing will reduce the efficiency by 2 % to 3 %.

**Overview of product features**

Material variants G1, G3

Feature	Motor version					
	UAG	UTG/XTG			UTG	
<b>Motor size</b>						
4-pole	16 4 ... 40 4	-	-	-	-	-
6-pole	6 6 ... 40 6	80 6 ... 120 6	-	-	-	-
8-pole	6 8 ... 18 8	30 8 ... 100 8	120 8 ... 160 8	-	-	-
10-pole	-	-	40 10 ... 120 10	155 10 ... 250 10	-	-
12-pole	-	-	-	130 12 ... 190 12	251 12 ... 410 12	-
14-pole	-	-	-	-	340 14	370 14 ... 550 14
<b>Explosion protection</b>						
Version U...	Not explosion-proof			Not explosion-proof <sup>6)</sup>		Not explosion-proof
Version X...	-	 or  Explosion-proof Class I, Division 1, Groups C & D, T3		-		-
<b>Motor</b>						
Starting method	DOL	DOL or star-delta				DOL
Voltage	460 V <sup>7)</sup>					460 V
Cooling	Cooled by surrounding fluid					
Immersion depth	40 ft [12 m] max.					
<b>Power cable</b>						
Type	See table "Overview of power cables"					
Length	33 ft [10 m] <sup>8)</sup>					
Cable entry	Absolutely watertight					
<b>Sealing elements</b>						
Elastomer seals	Nitrile butadiene rubber NBR <sup>9)</sup>					
Shaft seal	Bellows-type mechanical seal <sup>10)</sup>					Mechanical seal with covered spring
<b>Monitoring equipment</b>						
Winding temperature	PTC thermistor					
Bearing temperature	Pump end PT100 Drive end PT100	Pump end PT100 <sup>11)</sup>				Pump end PT100 Drive end PT100
Leakage in the motor space	Electrode monitoring the winding space for leakage	Electrode monitoring the winding and connection space for leakage				
Mechanical seal leakage	Float switch in leakage area					
Vibration sensor	-	- <sup>12)</sup>				
Casing wear ring	Standard design <sup>13)</sup>					
Coating	Environmentally friendly KSB standard coating, color RAL 5002 <sup>14)</sup>					
Installation	(⇒ Page 45)					
<b>Maximum temperature of fluid handled</b>						
Material variant G1	104 °F [40 °C]					
Material variant G3	77 °F [25 °C]					
<b>Tests/inspections</b>						
Hydraulic system	KSB standard (ZN 56525) <sup>15)</sup>					
General	KSB standard (ZN 56525)					

6) Optional: Non-incendive Class I, Division 2, Groups A, B, C&amp;D, T3

7) Optional: 380 V, 575 V

8) Optional: up to 165 ft [50 m]

9) Optional: Viton = fluorocarbon rubber FPM

10) On P1500-1060 mechanical seal with covered spring

11) Optional: Drive-end PT100

12) Optional: internal vibration sensor

13) Optional: casing wear ring with groove for flushing (PA 1500-1060 and PA 1600-1060 are not fitted with a casing wear ring; as an option they can only be fitted with a casing wear ring with groove for flushing)

14) Optional: 250 µm

15) Optional: Hydraulic Institute, Level B



Overview of power cables

Feature	S1BN8-F rubber-sheathed cable	S07RC4N8-F rubber-sheathed cable
Type	Standard	Optional
Rated voltage	1000 V	750 V
EMC screening	-	✓
Insulation material	EPR <sup>16)</sup>	EPR <sup>16)</sup>
Max. continuous temperature of insulation	194 °F [90 °C]	194 °F [90 °C]
For permanent immersion in waste water to DIN VDE 0282-16/HD22.16	✓	✓

**Related documents**

- General Arrangement Drawings 1580.396
- Motor Data Booklet 1580.566
- Planning Information 0118.55

---

<sup>16)</sup> EPR = ethylene propylene rubber

### Data to be indicated in the purchase order

- Designation of the pump (see section Designation)
- Flow rate Q, head  $H_{total}$
- Head  $H_{total}$
- Type and temperature of fluid handled
- Voltage, frequency, starting method, cable length
- Required accessories
  - For discharge tubes indicate all required elevations and the type of installation.
  - For flow-straightening vanes indicate the type of installation and whether the design is with or without suction umbrella.
  - For a support rope indicate dimension "L", the number of additional lifting rings (depending on the lifting height of the lifting equipment) as well as the elevations and type of installation.
- Quantity and language of operating manuals

1	Suspension arrangement attached to cover (or cross beam for BU/BG)
2	Lifting ring (standard, included in the scope of supply)
3	Optional (intermediate) lifting ring(s)
4	Lower edge of discharge tube = lower edge of pump

The support rope is an accessory and can be supplied with additional lifting rings and a support spacer (⇒ Page 49) as an option. The standard design is supplied without intermediate lifting ring(s).

Always define dimension "L" when ordering a support rope to allow the correct length to be determined. The lifting height of the crane must be taken into account when ordering a support rope. This determines the number of lifting rings required for installing the pump in or removing it from the discharge tube.

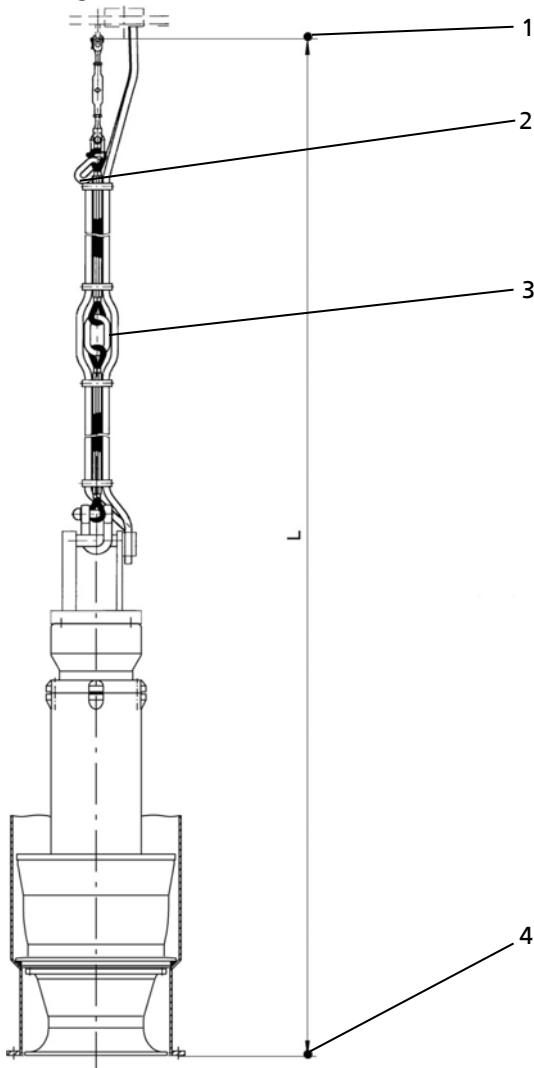

## Material combinations

Overview of materials

Part No.	Description	G1	G3 <sup>17)</sup> (seawater variant)
112	Pump bowl		A 48 Class 30 B
138	Bellmouth		A 48 Class 30 B
230	Impeller		A 890 CD 4 MCu
350/330	Bearing housing / bearing bracket		A 48 Class 40 B
360	Bearing cover		A 48 Class 40 B
412	O-ring		NBR <sup>18)</sup> (Viton-FPM) <sup>19)</sup>
433	Mechanical seal (pump end)		SiC /SiC (bellows NBR <sup>18)</sup> , Viton-FPM <sup>18)</sup> )
	Mechanical seal (drive end)		Carbon/SiC (bellows NBR <sup>18)</sup> , Viton-FPM <sup>18)</sup> )
502	Casing wear ring		Stainless steel
571	Bail		A 536: 60-40-18 / A 284 B <sup>20)</sup>
811	Motor housing		A 48 Class 40 B
812	Motor housing cover		A 48 Class 40 B
818	Shaft (rotor)	A 276 Type 420	A 276 Type 431
834	Cable gland		-
	Gland housing		A 48 Class 40 B
Various	Screws/bolts		Stainless steel
99-16	Anode	-	Zn
Other materials on request.			

Comparison of materials

EN	ASTM
EN-GJL-200 (JL 1030)	A 48 Class 30 B
EN-GJL-250 (JL 1040)	A 48 Class 40 B
1.4517	A 890 CD 4 MCu
1.4021	A 276 Type 420
1.4057	A 276 Type 431
NBR	NBR
FPM	FKM
EN-GJS-400-15 (JS 1030)	A 536: 60-40-18
S235JR	A 284 B

## Description of materials

### Duplex stainless steel (1.4517 or technically equivalent material)

This type of cast steel is resistant to cavitation, has excellent strength values and is used for high circumferential speeds. An excellent resistance to pitting corrosion makes ferritic-austenitic stainless steel a popular choice for pumping acidic waste water with a high chloride content as well as seawater and brackish water. Thanks to its good chemical resistance, e.g. also against waste water containing phosphorous and sulphuric acid, this material is used in a wide range of applications in the chemical industry and process engineering. Pumps made of duplex stainless steel have a very long service life, even when handling brines, chemical waste water (pH 1–12), gray water and landfill leachate.

<sup>17)</sup> Pump set with cathodic protection (anodes to be checked every 6 to 12 months) and top coat of 250 µm

<sup>18)</sup> Nitrile rubber (Perbunan)

<sup>19)</sup> FPM fluorocarbon rubber variant available as an option against a surcharge

<sup>20)</sup> A536: 60-40-18 for motors: 80 6 ... 120 6, 30 8 ... 160 8, 40 10 ... 120 10; all other motors A 284 B

Selection chart

Amacan P, n = 1750 / 1160 / 875 / 700 / 585 / 500 rpm

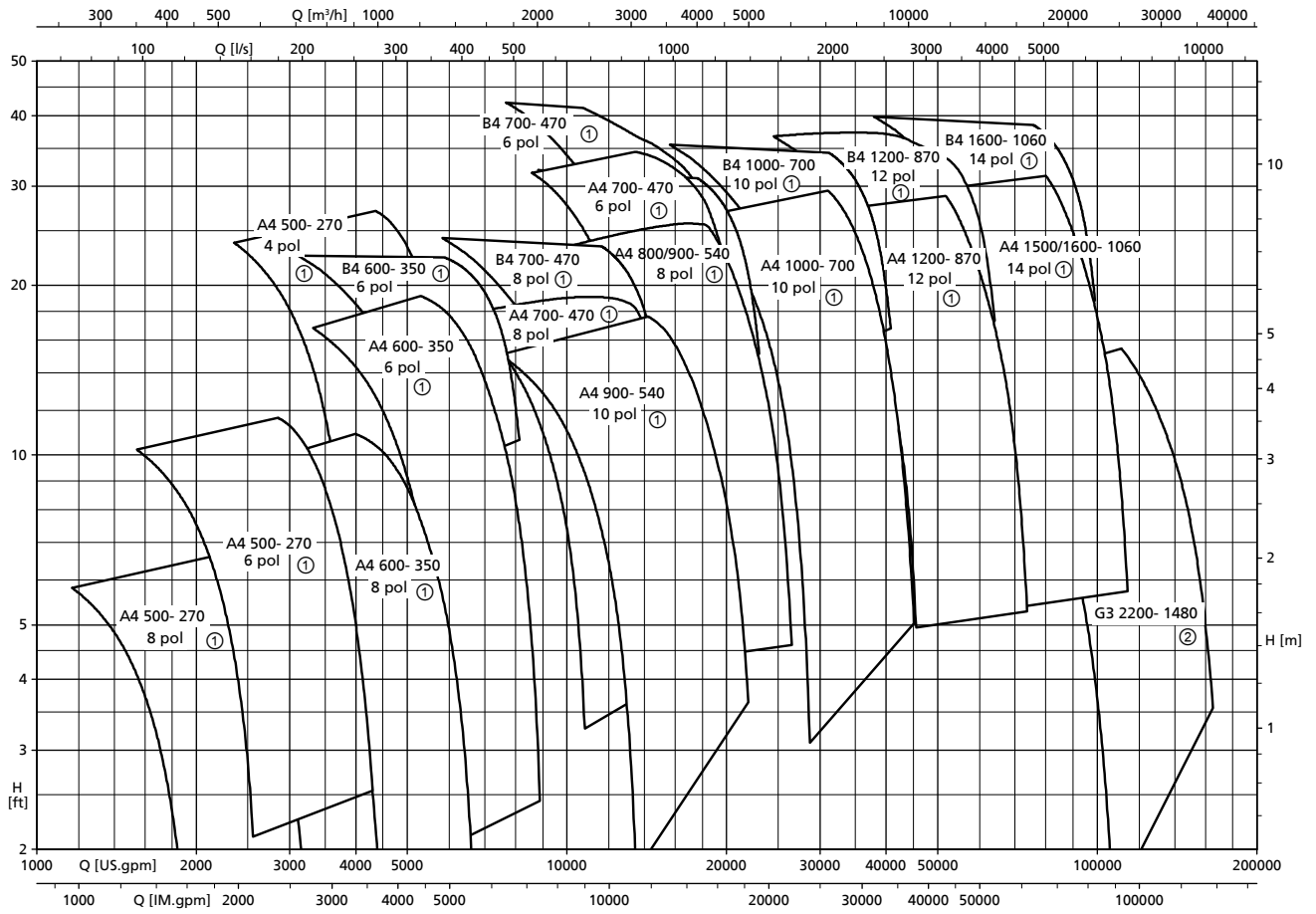

- ① Standard range
- ② Special range on request

Characteristic curves

n = 1750 rpm

Amacan PA4 500-270, n = 1750 rpm

Characteristic curves to ISO 9906 / 2 / 2B. n = rated speed

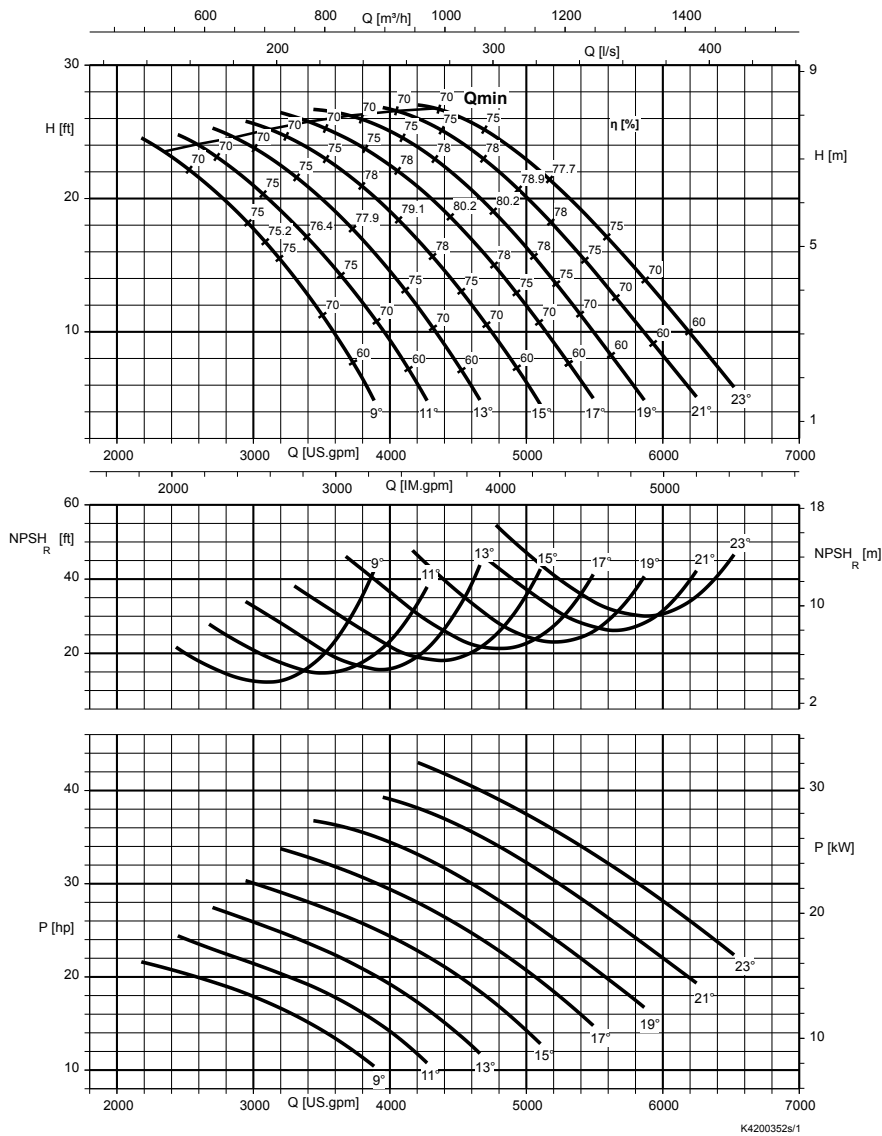

Free passage

Angle [°]	Free passage		Angle [°]	Free passage	
	[inch]	[mm]		[inch]	[mm]
23	2 3/4	70	15	2	50
21	2 1/2	65	13	1 3/4	45
19	2 3/8	60	11	1 1/2	40
17	2 1/8	55	9	1 3/8	35

Rated power P<sub>2</sub> and mass moment of inertia J<sup>21)</sup>

Size	Rated power P <sub>2</sub>				Mass moment of inertia J
	UAG		XAG		
	[hp]	[kW]	[hp]	[kW]	
PA4 500-270 / 16 4	20	16	–	–	0.16
PA4 500-270 / 20 4	33	25	–	–	0.19
PA4 500-270 / 32 4	43	32	–	–	0.23
PA4 500-270 / 40 4	53	40	–	–	0.23

21) These values are valid for a density = 1 kg/dm<sup>3</sup> and a kinematic viscosity of up to 20 mm<sup>2</sup>/s.

n = 1160 rpm<sup>1</sup>

**Amacan PA4 500-270, n = 1160 rpm**

Characteristic curves to ISO 9906 / 2 / 2B. n = rated speed

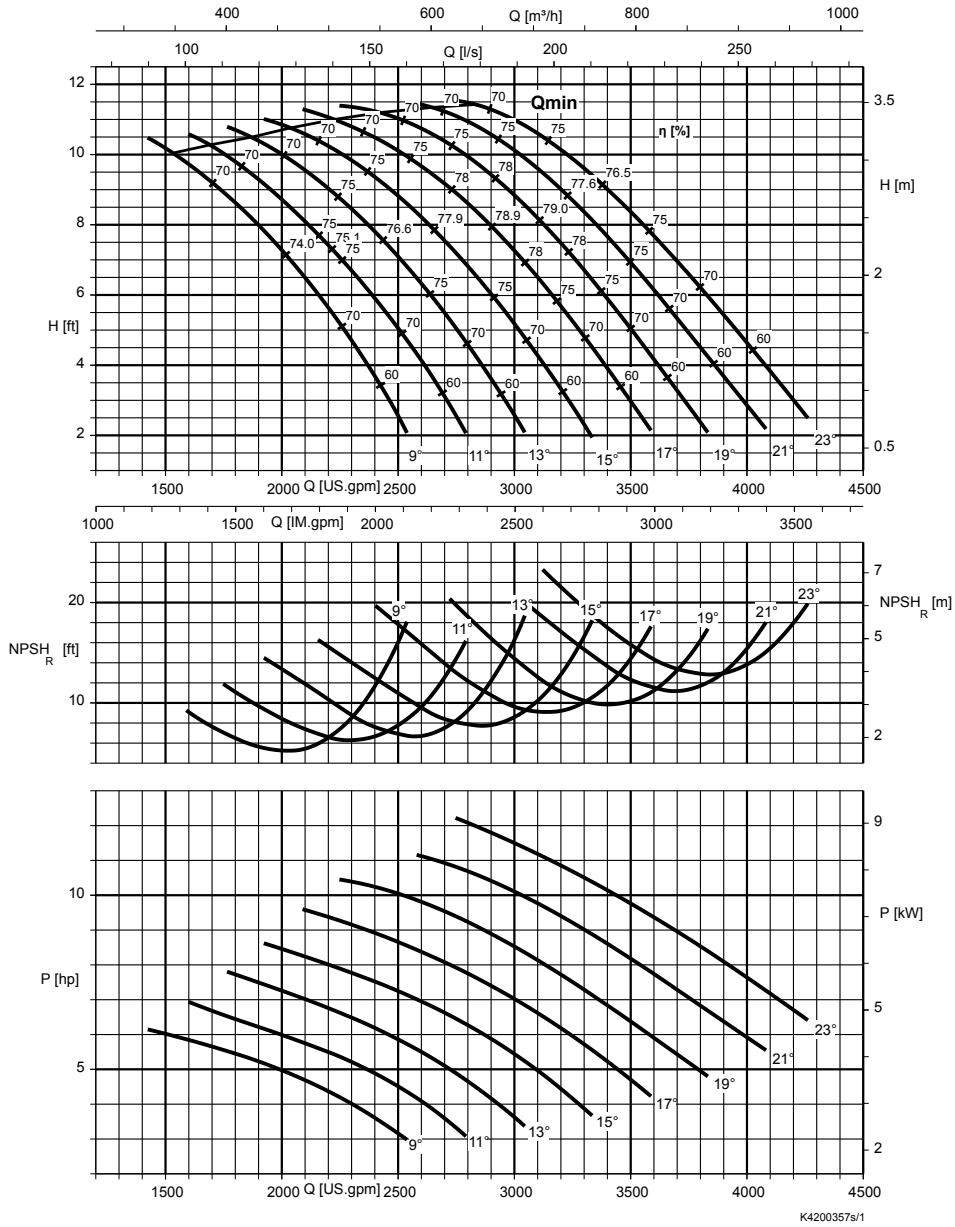

Free passage

Angle [°]	Free passage		Angle [°]	Free passage	
	[inch]	[mm]		[inch]	[mm]
23	2 3/4	70	15	2	50
21	2 1/2	65	13	1 3/4	45
19	2 3/8	60	11	1 1/2	40
17	2 1/8	55	9	1 3/8	35

Rated power P<sub>2</sub> and mass moment of inertia J<sup>22)</sup>

Size	Rated power P <sub>2</sub>				Mass moment of inertia J
	UAG		XAG		
	[hp]	[kW]	[hp]	[kW]	
PA4 500-270 / 6 6	10	7.5	-	-	0.17
PA4 500-270 / 10 6	15	12	-	-	0.17

22) These values are valid for a density = 1 kg/dm<sup>3</sup> and a kinematic viscosity of up to 20 mm<sup>2</sup>/s.

## Amacan PA4 600-350, n = 1160 rpm

Characteristic curves to ISO 9906 / 2 / 2B. n = rated speed

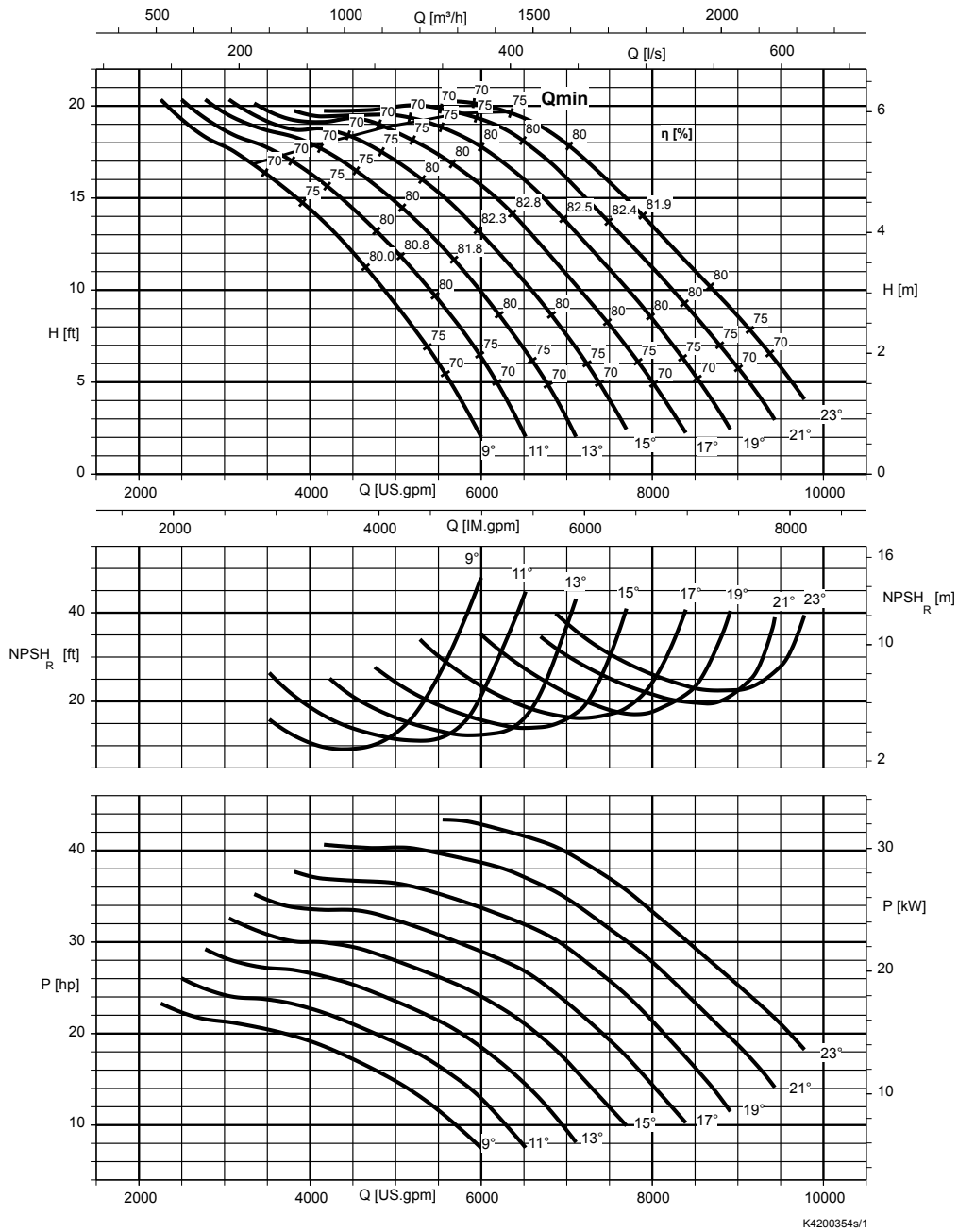

### Free passage

Angle [°]	Free passage		Angle [°]	Free passage	
	[inch]	[mm]		[inch]	[mm]
23	3 3/8	85	15	2 1/2	65
21	3 1/8	80	13	2 3/8	60
19	3	75	11	2 1/8	55
17	2 3/4	70	9	2	50

### Rated power P<sub>2</sub> and mass moment of inertia J<sup>23)</sup>

Size	Rated power P <sub>2</sub>				Mass moment of inertia J
	UAG		XAG		
	[hp]	[kW]	[hp]	[kW]	[kgm²]
PA4 600-350 / 16 6	25	18	-	-	0.41
PA4 600-350 / 25 6	37	28	-	-	0.47
PA4 600-350 / 40 6	50	38	-	-	0.51

23) These values are valid for a density = 1 kg/dm<sup>3</sup> and a kinematic viscosity of up to 20 mm<sup>2</sup>/s.

### Amacan PA4 700-470, n = 1160 rpm

Characteristic curves to ISO 9906 / 2 / 2B. n = rated speed

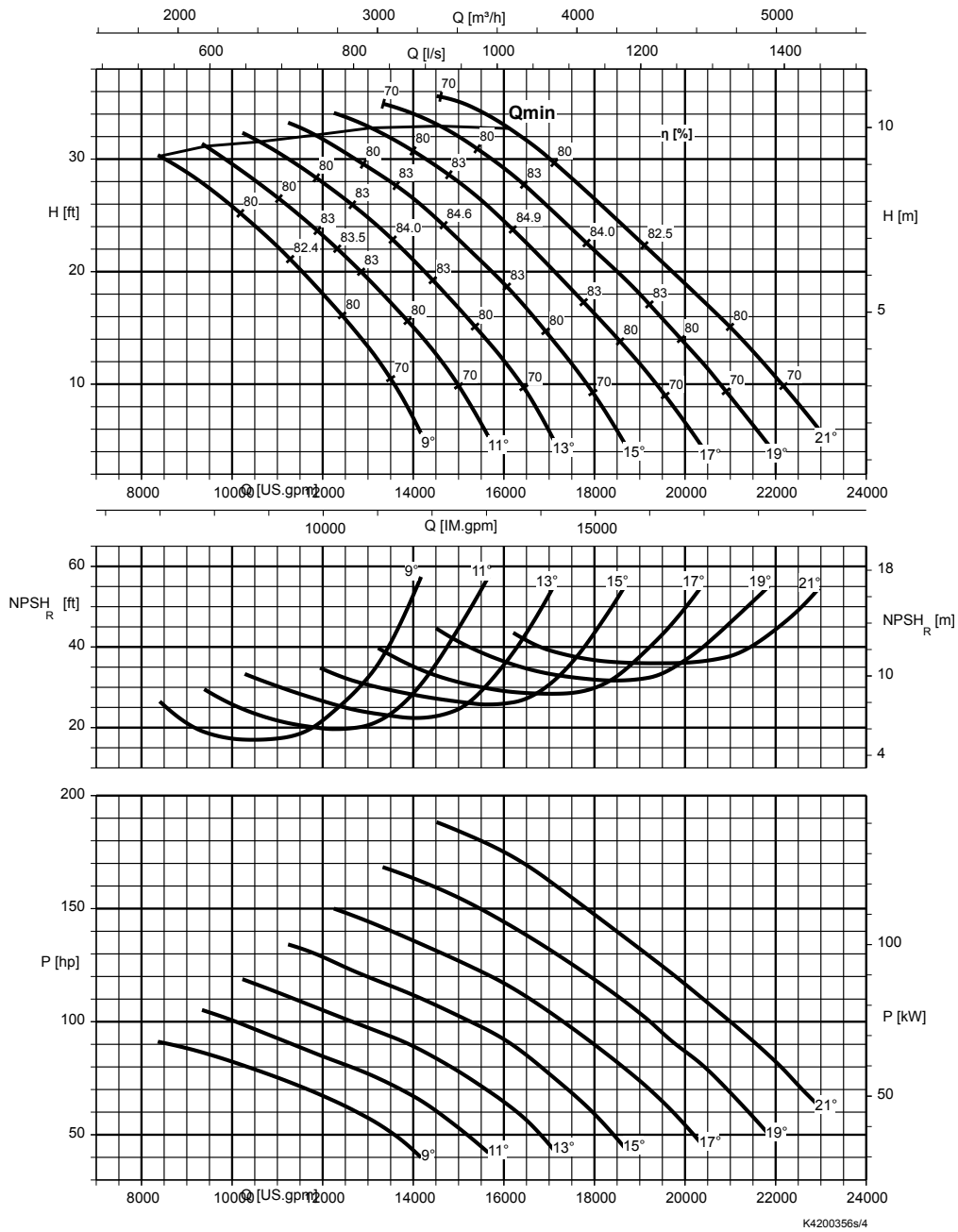

#### Free passage

Angle [°]	Free passage		Angle [°]	Free passage	
	[inch]	[mm]		[inch]	[mm]
21	4 3/8	110	13	3	75
19	4	100	11	2 5/8	68
17	3 5/8	93	9	2 3/8	60
15	3 3/8	85			

#### Rated power P<sub>2</sub> and mass moment of inertia J<sup>24)</sup>

Size	Rated power P <sub>2</sub>				Mass moment of inertia J
	UTG		XTG		
	[hp]	[kW]	[hp]	[kW]	[kgm²]
PA4 700-470 / 80 6	100	80	100	80	1.95
PA4 700-470 / 100 6	135	100	135	100	2.08
PA4 700-470 / 120 6	154	115	154	115	2.22

24) These values are valid for a density = 1 kg/dm<sup>3</sup> and a kinematic viscosity of up to 20 mm<sup>2</sup>/s.



## Amacan PB4 600-350, n = 1160 rpm

Characteristic curves to ISO 9906 / 2 / 2B. n = rated speed

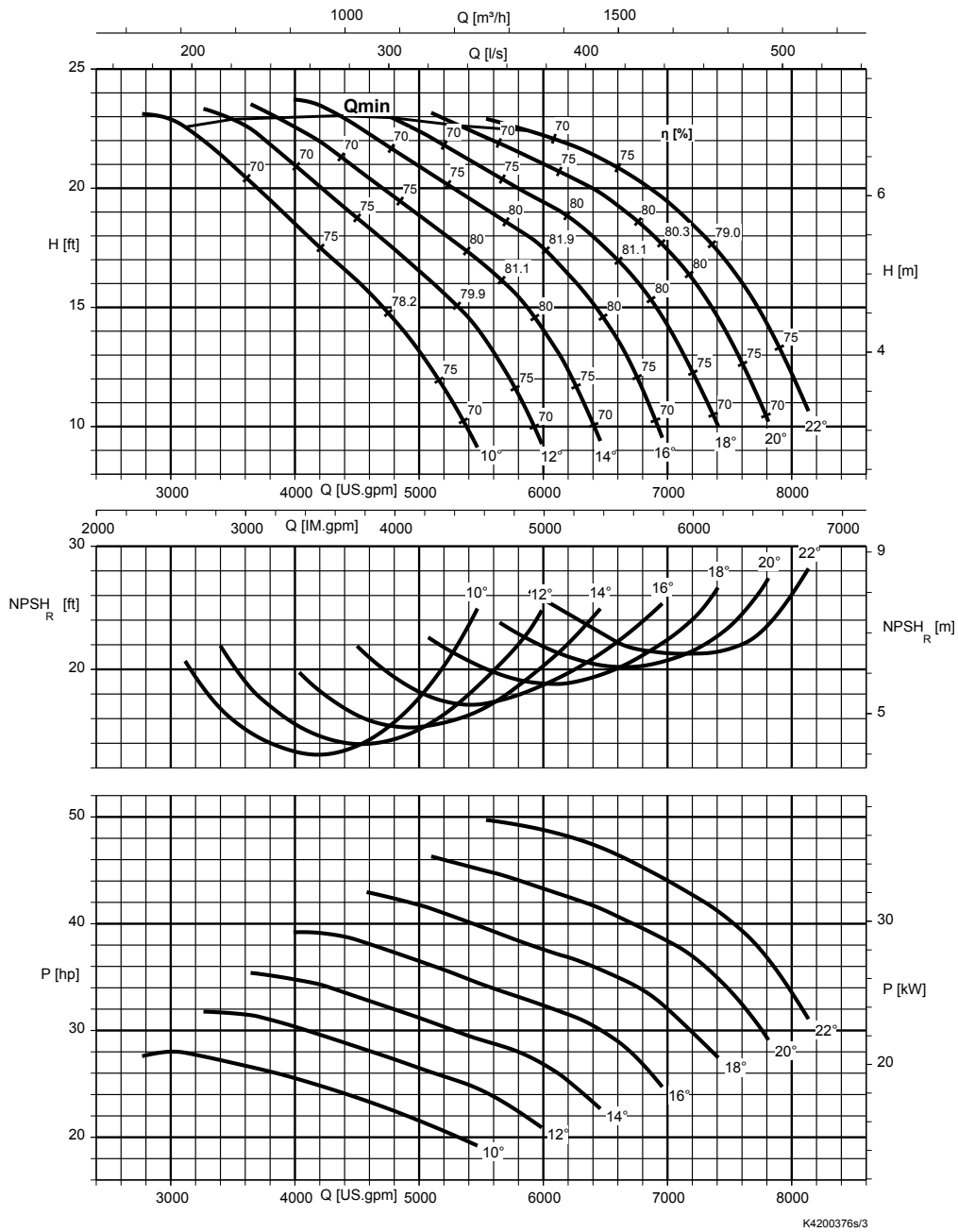

### Free passage

Angle [°]	Free passage		Angle [°]	Free passage	
	[inch]	[mm]		[inch]	[mm]
22	3 3/8	85	14	2 1/2	65
20	3 1/8	80	12	2 3/8	60
18	3	75	10	2 1/8	55
16	2 3/4	70			

### Rated power P<sub>2</sub> and mass moment of inertia J<sup>25)</sup>

Size	Rated power P <sub>2</sub>				Mass moment of inertia J
	UAG		XAG		
	[hp]	[kW]	[hp]	[kW]	[kgm²]
PB4 600-350 / 25 6	37	28	-	-	0.47
PB4 600-350 / 40 6	50	38	-	-	0.51

25) These values are valid for a density = 1 kg/dm<sup>3</sup> and a kinematic viscosity of up to 20 mm<sup>2</sup>/s.

## Amacan PB4 700-470, n = 1160 rpm

Characteristic curves to ISO 9906 / 2 / 2B. n = rated speed

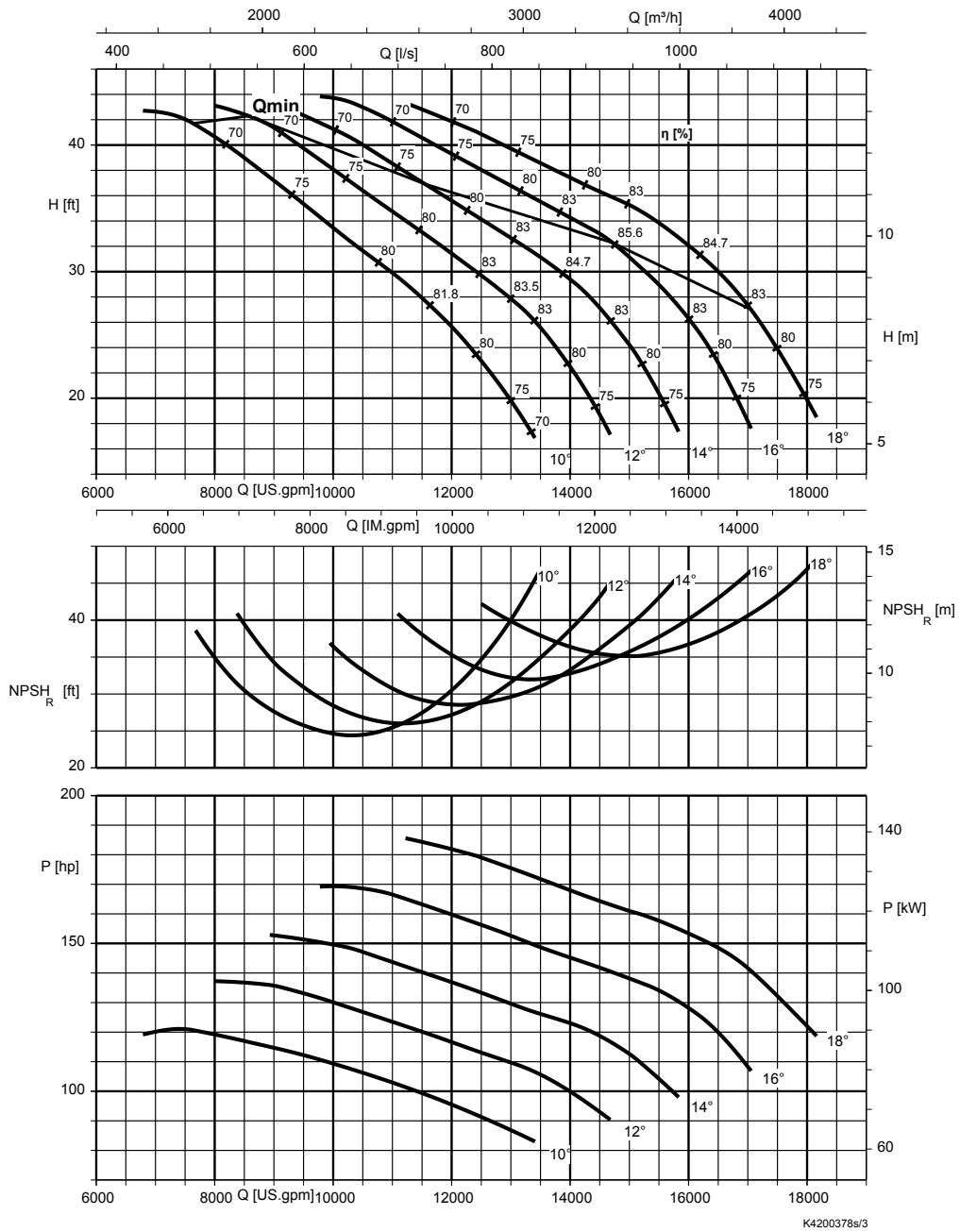

### Free passage

Angle [°]	Free passage		Angle [°]	Free passage	
	[inch]	[mm]		[inch]	[mm]
18	4	100	12	3	75
16	3 5/8	93	10	2 5/8	68
14	3 3/8	85			

### Rated power P<sub>2</sub> and mass moment of inertia J<sup>26)</sup>

Size	Rated power P <sub>2</sub>				Mass moment of inertia J
	UTG		XTG		
	[hp]	[kW]	[hp]	[kW]	[kgm²]
PB4 700-470 / 100 6	135	100	135	100	2.08
PB4 700-470 / 120 6	154	115	154	115	2.22

26) These values are valid for a density = 1 kg/dm<sup>3</sup> and a kinematic viscosity of up to 20 mm<sup>2</sup>/s.

n = 875 rpm

## Amacan PA4 500-270, n = 875 rpm

Characteristic curves to ISO 9906 / 2 / 2B. n = rated speed

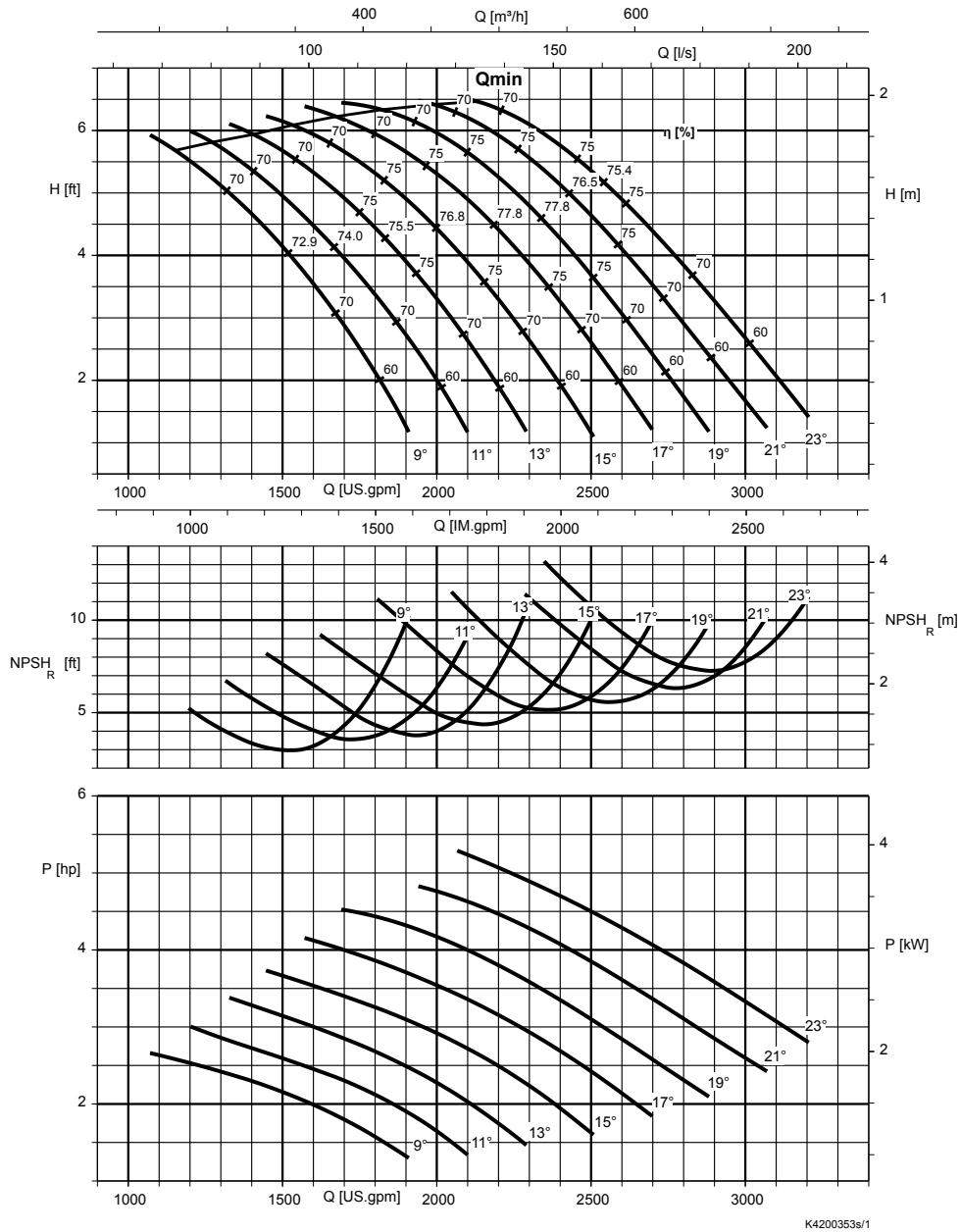

### Free passage

Angle [°]	Free passage		Angle [°]	Free passage	
	[inch]	[mm]		[inch]	[mm]
23	2 3/4	70	15	2	50
21	2 1/2	65	13	1 3/4	45
19	2 3/8	60	11	1 1/2	40
17	2 1/8	55	9	1 3/8	35

### Rated power P<sub>2</sub> and mass moment of inertia J<sup>27)</sup>

Size	Rated power P <sub>2</sub>				Mass moment of inertia J
	UAG		XAG		
	[hp]	[kW]	[hp]	[kW]	[kgm²]
PA4 500-270 / 6 8	7.5	6	-	-	0.17

27) These values are valid for a density = 1 kg/dm<sup>3</sup> and a kinematic viscosity of up to 20 mm<sup>2</sup>/s.

## Amacan PA4 600-350, n = 875 rpm

Characteristic curves to ISO 9906 / 2 / 2B. n = rated speed

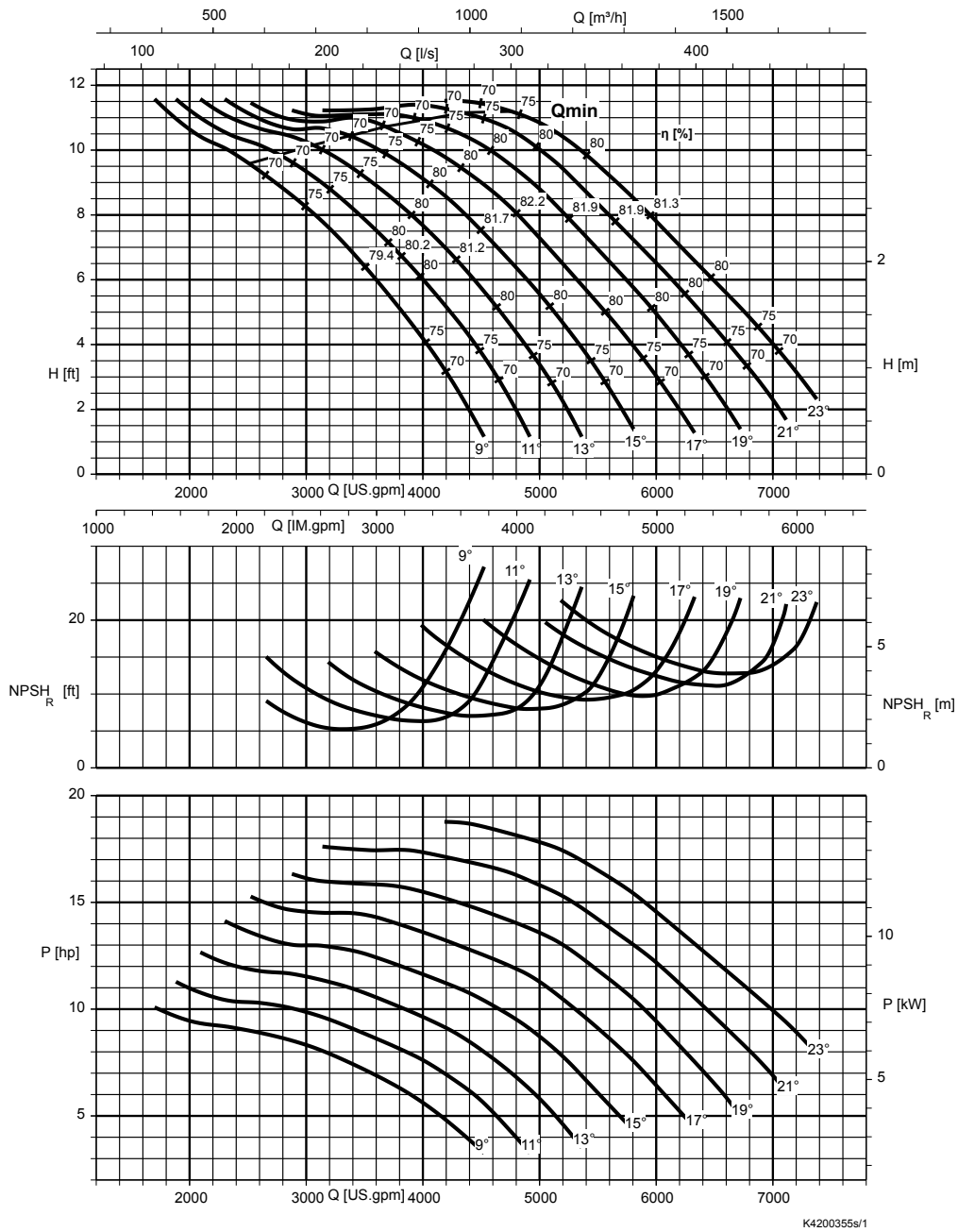

### Free passage

Angle [°]	Free passage		Angle [°]	Free passage	
	[inch]	[mm]		[inch]	[mm]
23	3 3/8	85	15	2 1/2	65
21	3 1/8	80	13	2 3/8	60
19	3	75	11	2 1/8	55
17	2 3/4	70	9	2	50

### Rated power P<sub>2</sub> and mass moment of inertia J<sup>28)</sup>

Size	Rated power P <sub>2</sub>				Mass moment of inertia J [kgm²]
	UAG		XAG		
	[hp]	[kW]	[hp]	[kW]	
PA4 600-350 / 6 8	7.5	6	–	–	0.42
PA4 600-350 / 10 8	15	12	–	–	0.42
PA4 600-350 / 18 8	20	16	–	–	0.43

28) These values are valid for a density = 1 kg/dm<sup>3</sup> and a kinematic viscosity of up to 20 mm<sup>2</sup>/s.

## Amacan PA4 700-470, n = 875 rpm

Characteristic curves to ISO 9906 / 2 / 2B. n = rated speed

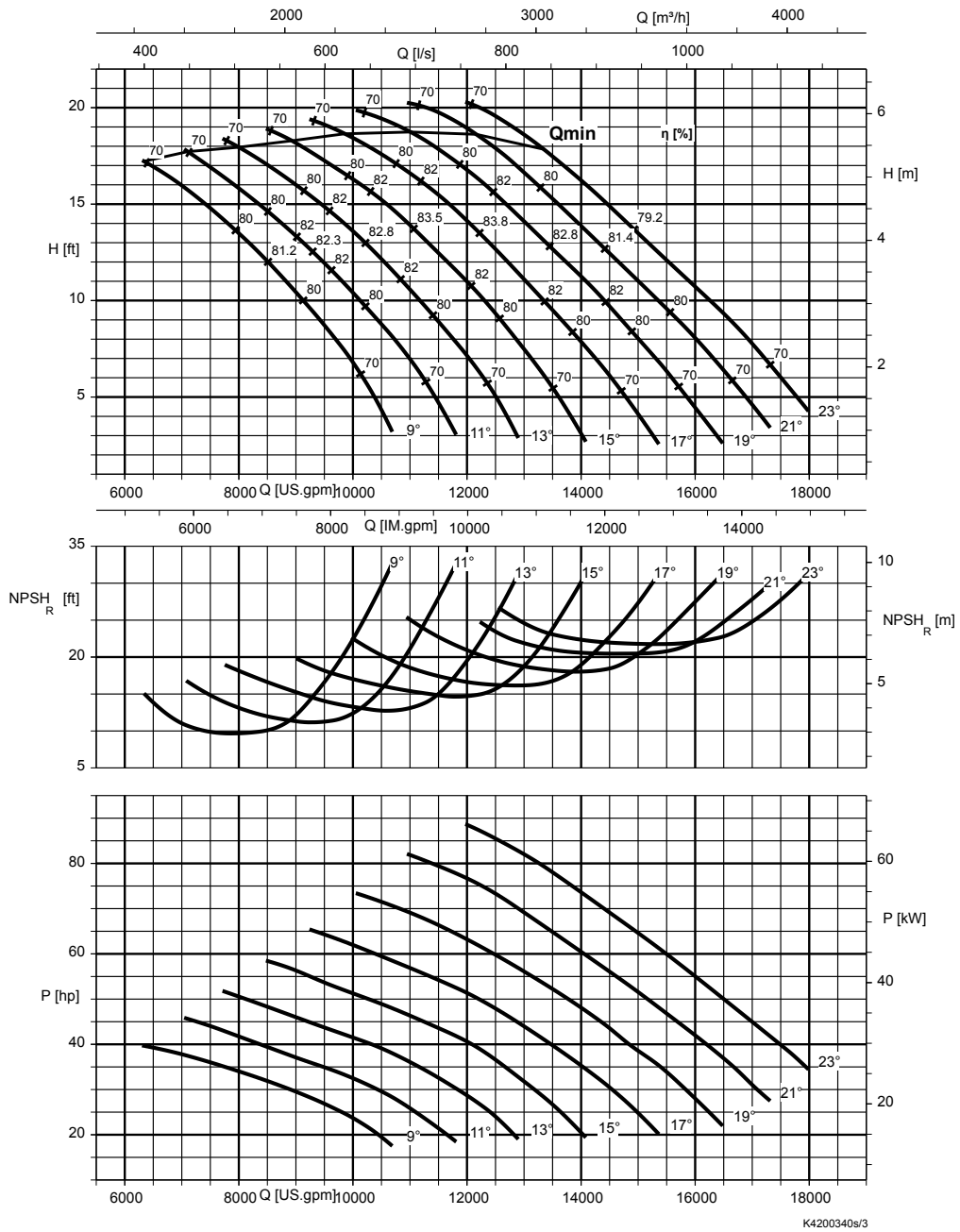

### Free passage

Angle [°]	Free passage		Angle [°]	Free passage	
	[inch]	[mm]		[inch]	[mm]
23	4 3/4	120	15	3 3/8	85
21	4 3/8	110	13	3	75
19	4	100	11	2 5/8	68
17	3 5/8	93	9	2 3/8	60

### Rated power P<sub>2</sub> and mass moment of inertia J<sup>29)</sup>

Size	Rated power P <sub>2</sub>				Mass moment of inertia J
	UTG		XTG		
	[hp]	[kW]	[hp]	[kW]	[kgm²]
PA4 700-470 / 30 8	40	30	40	30	1.78
PA4 700-470 / 40 8	55	40	55	40	1.78
PA4 700-470 / 55 8	75	55	75	55	1.95
PA4 700-470 / 70 8	95	70	95	70	1.95

29) These values are valid for a density = 1 kg/dm<sup>3</sup> and a kinematic viscosity of up to 20 mm<sup>2</sup>/s.

## Amacan PA4 800-540, n = 875 rpm

Characteristic curves to ISO 9906 / 2 / 2B. n = rated speed

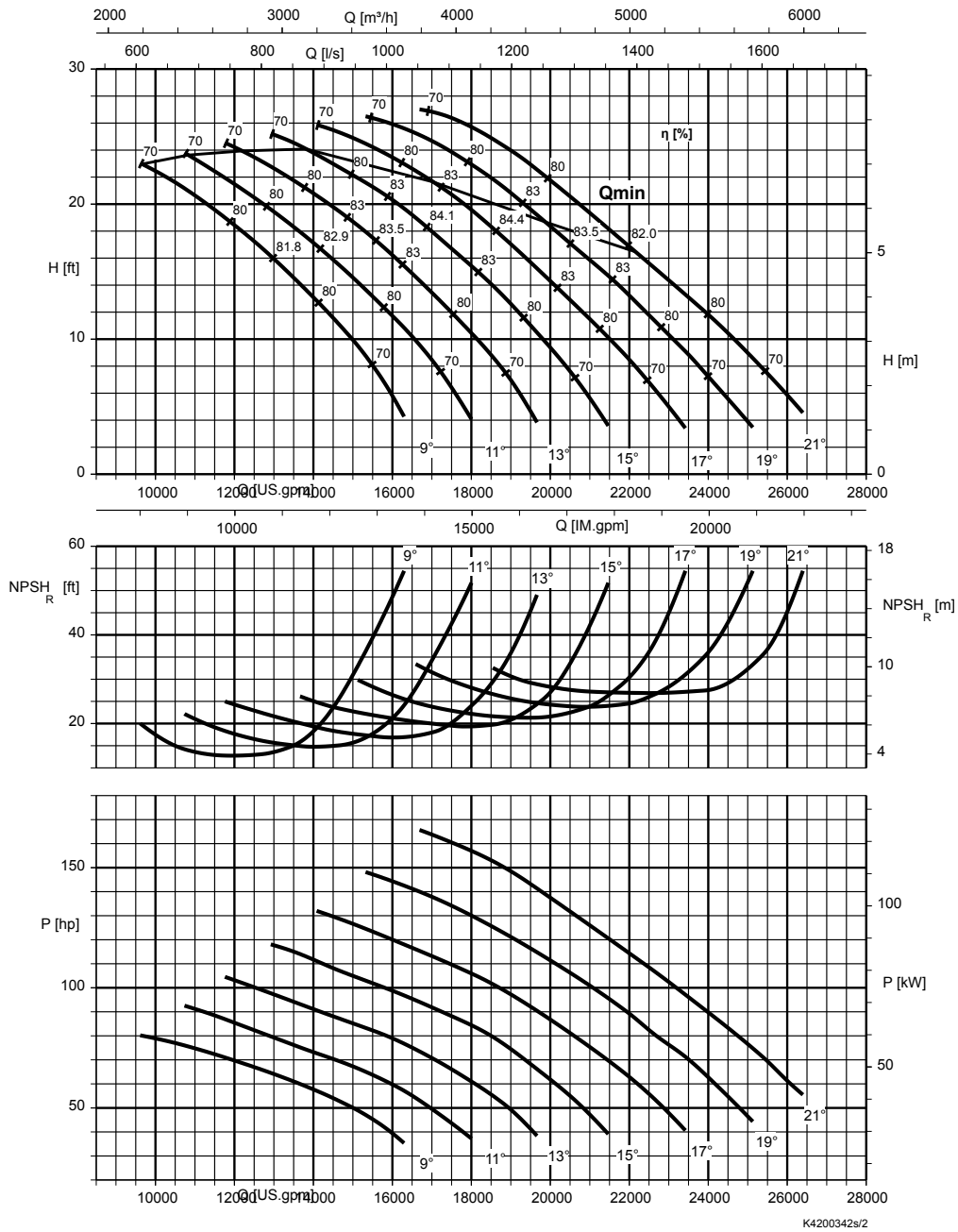

### Free passage

Angle [°]	Free passage		Angle [°]	Free passage	
	[inch]	[mm]		[inch]	[mm]
21	4 7/8	125	13	3 1/2	90
19	4 1/2	115	11	3 1/8	80
17	4 1/4	108	9	3	75
15	4	100			

### Rated power P<sub>2</sub> and mass moment of inertia J<sup>30)</sup>

Size	Rated power P <sub>2</sub>				Mass moment of inertia J
	UTG		XTG		
	[hp]	[kW]	[hp]	[kW]	[kgm²]
PA4 800-540 / 55 8	75	55	75	55	3.25
PA4 800-540 / 70 8	95	70	95	70	3.25
PA4 800-540 / 100 8	127	95	127	95	3.52

30) These values are valid for a density = 1 kg/dm<sup>3</sup> and a kinematic viscosity of up to 20 mm<sup>2</sup>/s.

## Amacan PA4 900-540, n = 875 rpm

Characteristic curves to ISO 9906 / 2 / 2B. n = rated speed

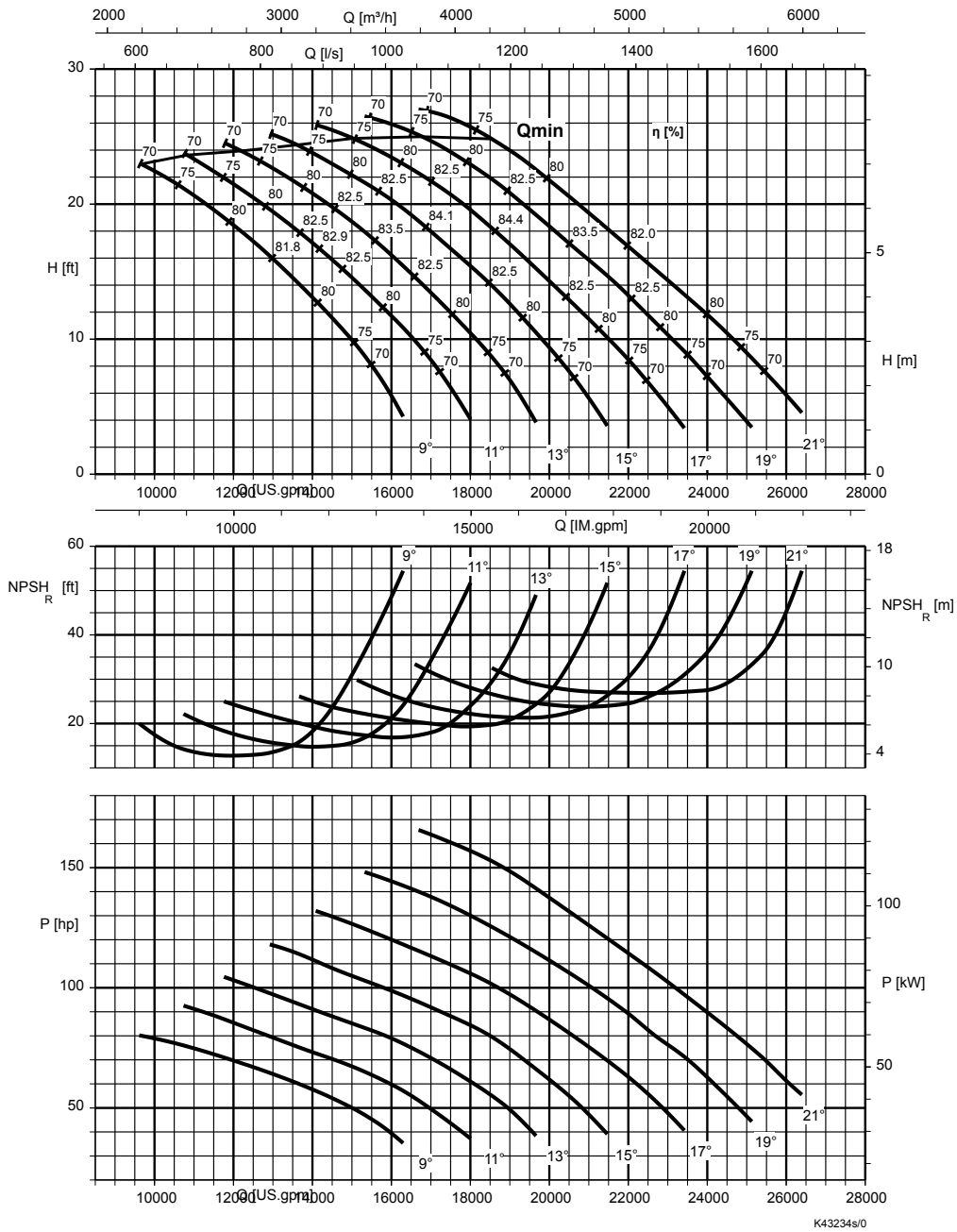

### Free passage

Angle [°]	Free passage		Angle [°]	Free passage	
	[inch]	[mm]		[inch]	[mm]
21	4 7/8	125	13	3 1/2	90
19	4 1/2	115	11	3 1/8	80
17	4 1/4	108	9	3	75
15	4	100			

### Rated power P<sub>2</sub> and mass moment of inertia J<sup>31)</sup>

Size	Rated power P <sub>2</sub>				Mass moment of inertia J
	UTG		XTG		
	[hp]	[kW]	[hp]	[kW]	[kgm <sup>2</sup> ]
PA4 900-540 / 120 8	160	120	160	120	4.53

31) These values are valid for a density = 1 kg/dm<sup>3</sup> and a kinematic viscosity of up to 20 mm<sup>2</sup>/s.

## Amacan PB4 700-470, n = 875 rpm

Characteristic curves to ISO 9906 / 2 / 2B. n = rated speed

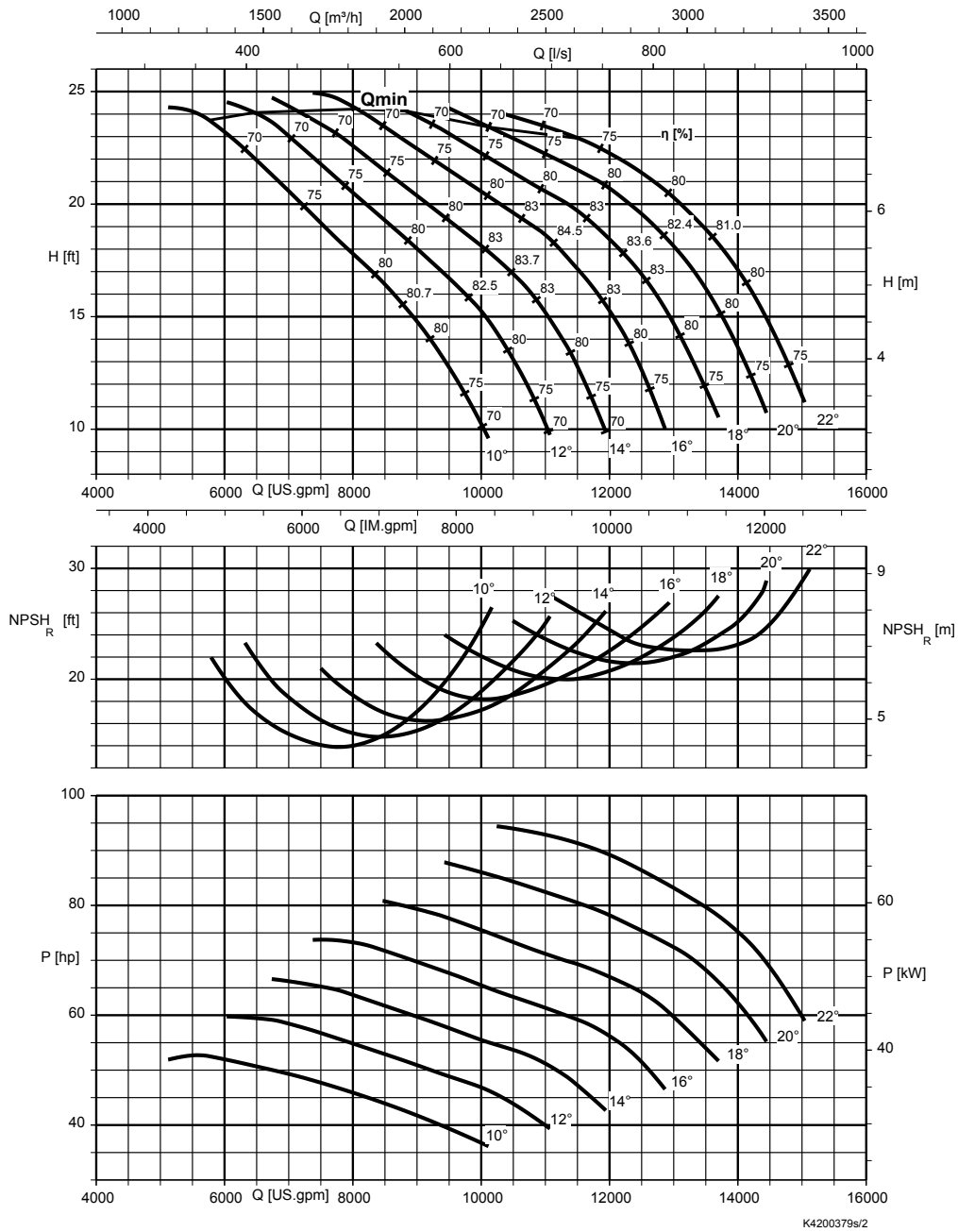

### Free passage

Angle [°]	Free passage		Angle [°]	Free passage	
	[inch]	[mm]		[inch]	[mm]
22	4 1/2	115	14	3 3/8	85
20	4 3/8	110	12	3	75
18	4	100	10	2 5/8	68
16	3 5/8	93			

### Rated power P<sub>2</sub> and mass moment of inertia J<sup>32)</sup>

Size	Rated power P <sub>2</sub>				Mass moment of inertia J
	UTG		XTG		
	[hp]	[kW]	[hp]	[kW]	[kgm²]
PB4 700-470 / 40 8	55	40	55	40	1.78
PB4 700-470 / 55 8	75	55	75	55	1.95
PB4 700-470 / 70 8	95	70	95	70	1.95
PB4 700-470 / 100 8	127	95	127	95	2.22

32) These values are valid for a density = 1 kg/dm<sup>3</sup> and a kinematic viscosity of up to 20 mm<sup>2</sup>/s.



### Amacan PB4 800-540, n = 875 rpm

Characteristic curves to ISO 9906 / 2 / 2B. n = rated speed

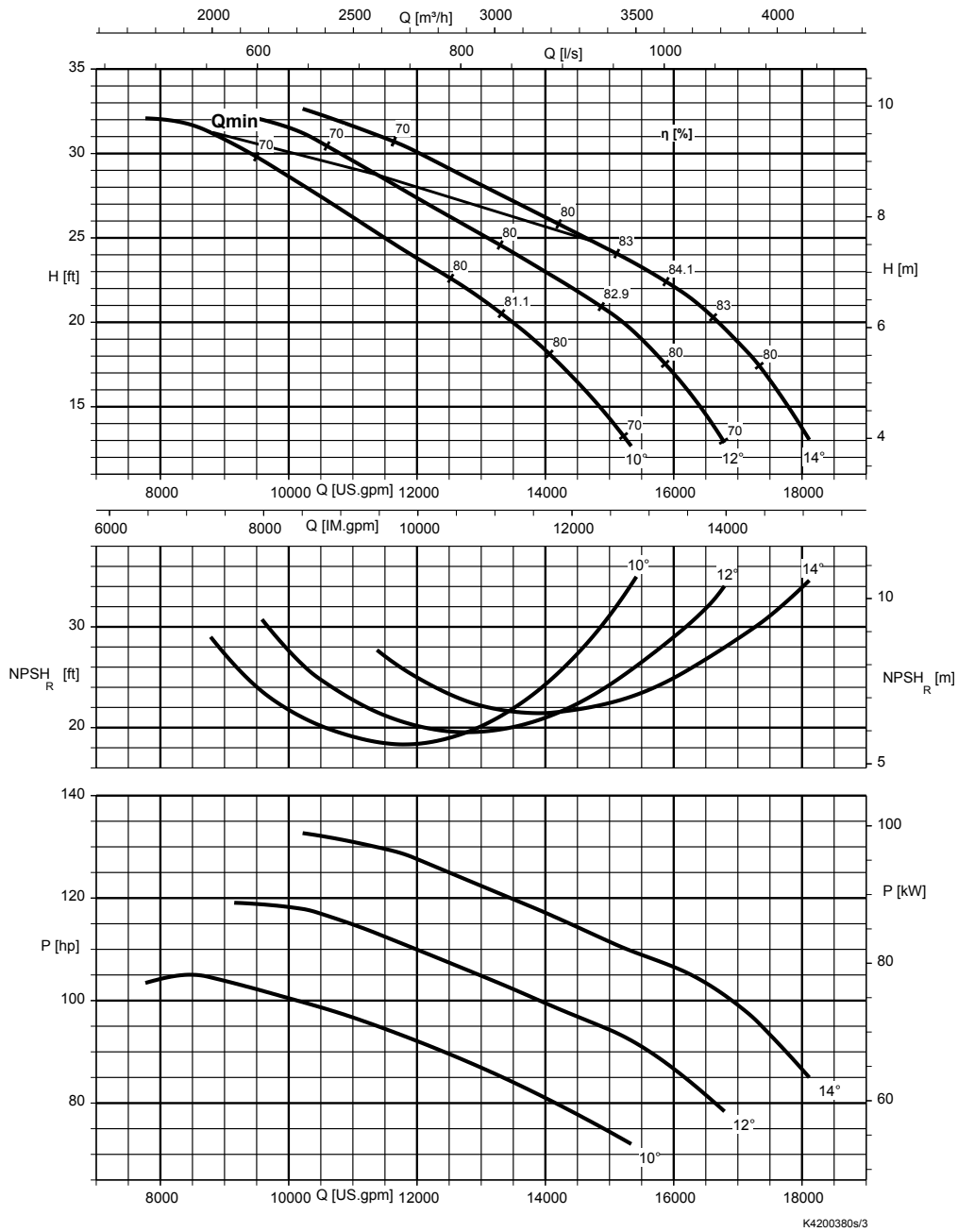

#### Free passage

Angle [°]	Free passage		Angle [°]	Free passage	
	[inch]	[mm]		[inch]	[mm]
14	4	100	10	3 1/8	80
12	3 1/2	90			

#### Rated power P<sub>2</sub> and mass moment of inertia J<sup>33)</sup>

Size	Rated power P <sub>2</sub>				Mass moment of inertia J
	UTG		XTG		
	[hp]	[kW]	[hp]	[kW]	[kgm <sup>2</sup> ]
PB4 800-540 / 70 8	95	70	95	70	3.25
PB4 800-540 / 100 8	127	95	127	95	3.52

33) These values are valid for a density = 1 kg/dm<sup>3</sup> and a kinematic viscosity of up to 20 mm<sup>2</sup>/s.

## Amacan PB4 900-540, n = 875 rpm

Characteristic curves to ISO 9906 / 2 / 2B. n = rated speed

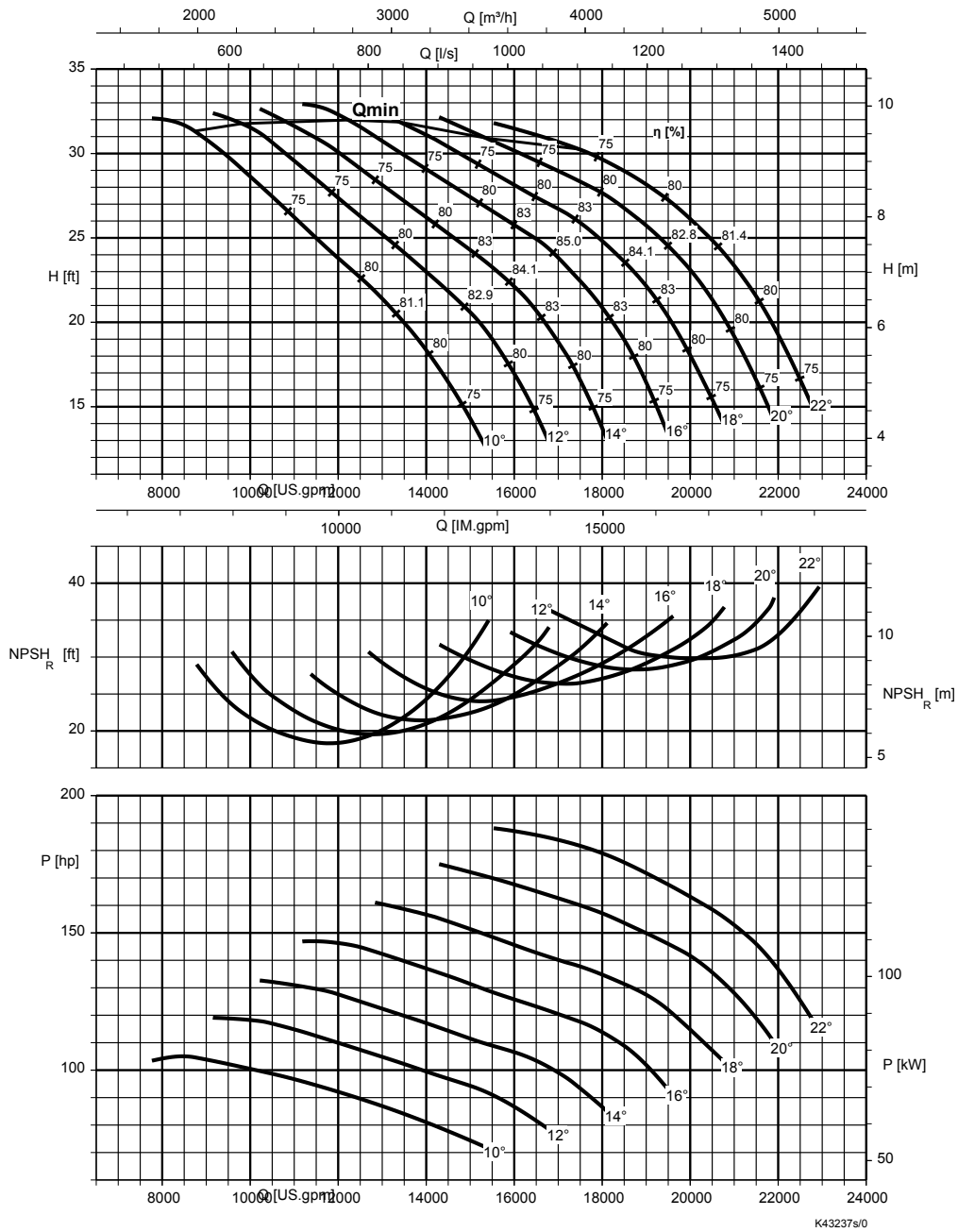

### Free passage

Angle [°]	Free passage		Angle [°]	Free passage	
	[inch]	[mm]		[inch]	[mm]
22	5 1/8	130	14	4	100
20	4 3/16	123	12	3 1/2	90
18	4 1/2	115	10	3 1/8	80
16	4 1/4	108			

### Rated power P<sub>2</sub> and mass moment of inertia J<sup>34)</sup>

Size	Rated power P <sub>2</sub>				Mass moment of inertia J
	UTG		XTG		
	[hp]	[kW]	[hp]	[kW]	[kgm²]
PB4 900-540 / 120 8	160	120	160	120	4.53
PB4 900-540 / 160 8	215	160	215	160	5.10

34) These values are valid for a density = 1 kg/dm<sup>3</sup> and a kinematic viscosity of up to 20 mm<sup>2</sup>/s.

n = 700 rpm

## Amacan PA4 900-540, n = 700 rpm

Characteristic curves to ISO 9906 / 2 / 2B. n = rated speed

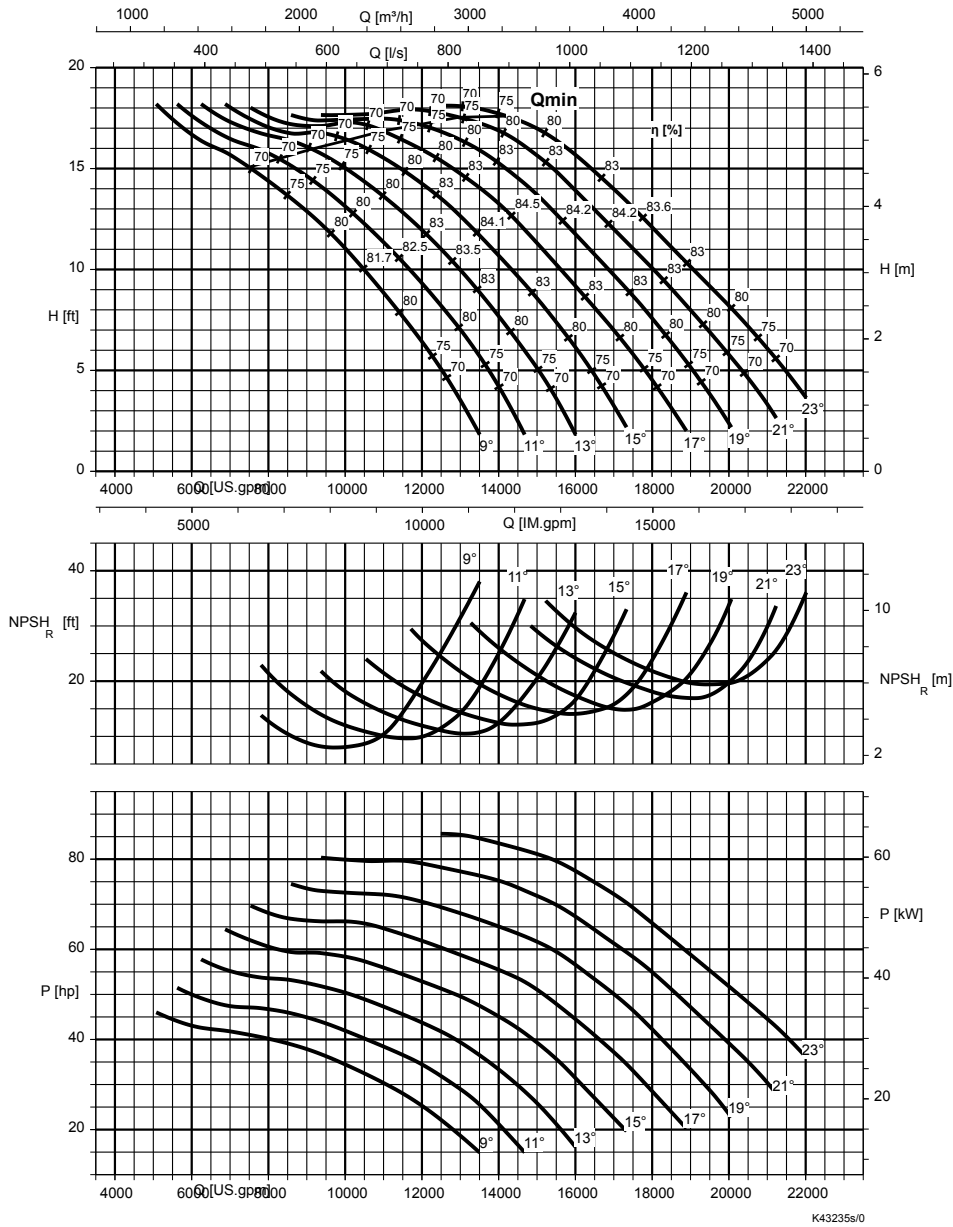

### Free passage

Angle	Free passage		Angle	Free passage	
[°]	[inch]	[mm]	[°]	[inch]	[mm]
23	5 1/4	135	15	4	100
21	4 7/8	125	13	3 1/2	90
19	4 1/2	115	11	3 1/8	80
17	4 1/4	108	9	3	75

### Rated power P<sub>2</sub> and mass moment of inertia J<sup>35)</sup>

Size	Rated power P <sub>2</sub>				Mass moment of inertia J
	UTG		XTG		
	[hp]	[kW]	[hp]	[kW]	
PA4 900-540 / 40 10	55	40	55	40	4.30
PA4 900-540 / 60 10	75	60	75	60	4.30
PA4 900-540 / 90 10	120	90	120	90	4.75

35) These values are valid for a density = 1 kg/dm<sup>3</sup> and a kinematic viscosity of up to 20 mm<sup>2</sup>/s.

## Amacan PA4 1000-700, n = 700 rpm

Characteristic curves to ISO 9906 / 2 / 2B. n = rated speed

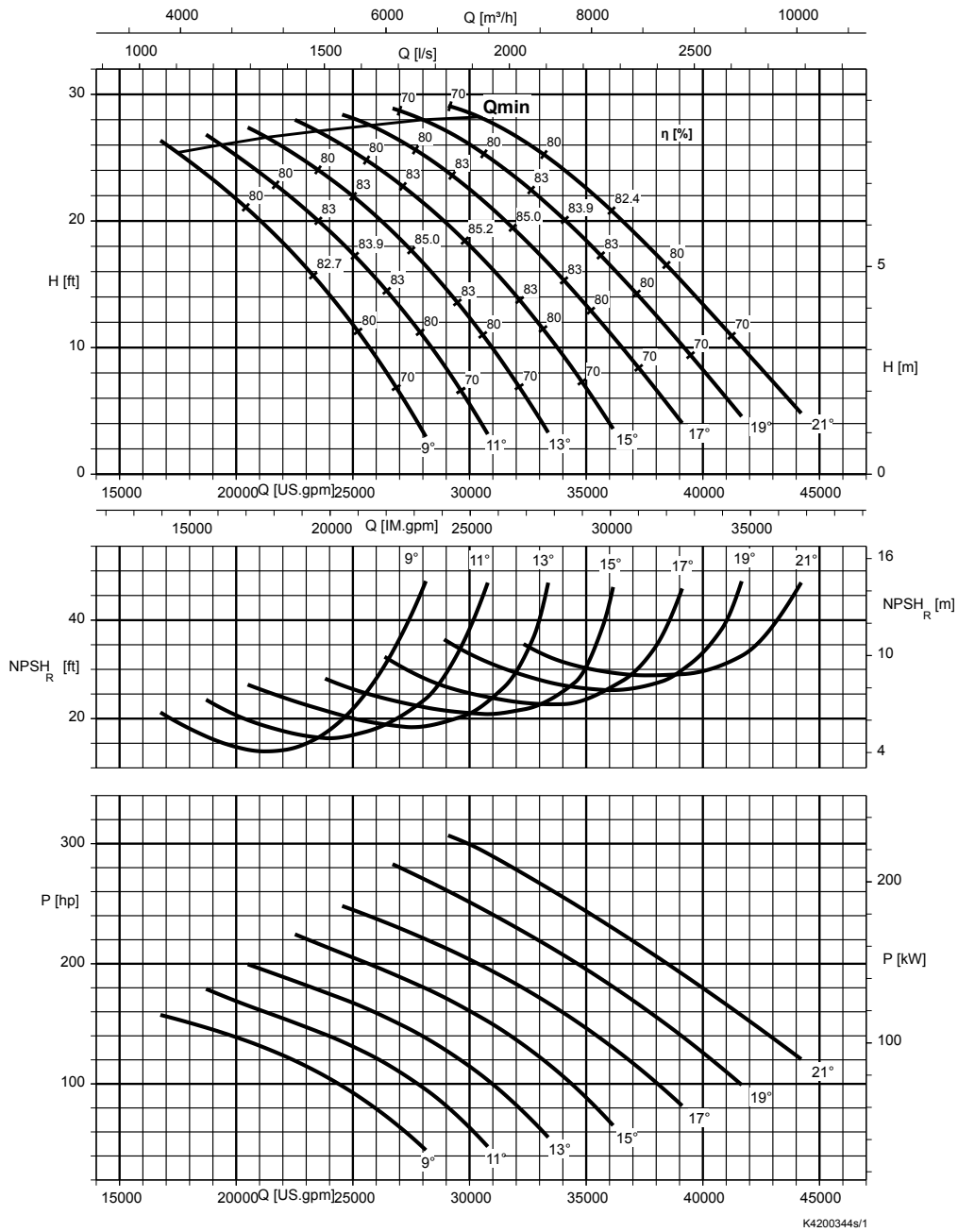

### Free passage

Angle [°]	Free passage		Angle [°]	Free passage	
	[inch]	[mm]		[inch]	[mm]
21	6 1/4	160	13	4 3/4	120
19	5 7/8	150	11	4 3/8	110
17	5 1/2	140	9	4	100
15	5 1/8	130			

### Rated power P<sub>2</sub> and mass moment of inertia J<sup>36)</sup>

Size	Rated power P <sub>2</sub>				Mass moment of inertia J
	UTG		XTG		
	[hp]	[kW]	[hp]	[kW]	[kgm²]
PA4 1000-700 / 120 10	160	120	160	120	11.5
PA4 1000-700 / 155 10	200	155	–	–	12.9
PA4 1000-700 / 200 10	270	200	–	–	17.0
PA4 1000-700 / 250 10	335	250	–	–	18.7

36) These values are valid for a density = 1 kg/dm<sup>3</sup> and a kinematic viscosity of up to 20 mm<sup>2</sup>/s.

## Amacan PB4 1000-700, n = 700 rpm

Characteristic curves to ISO 9906 / 2 / 2B. n = rated speed

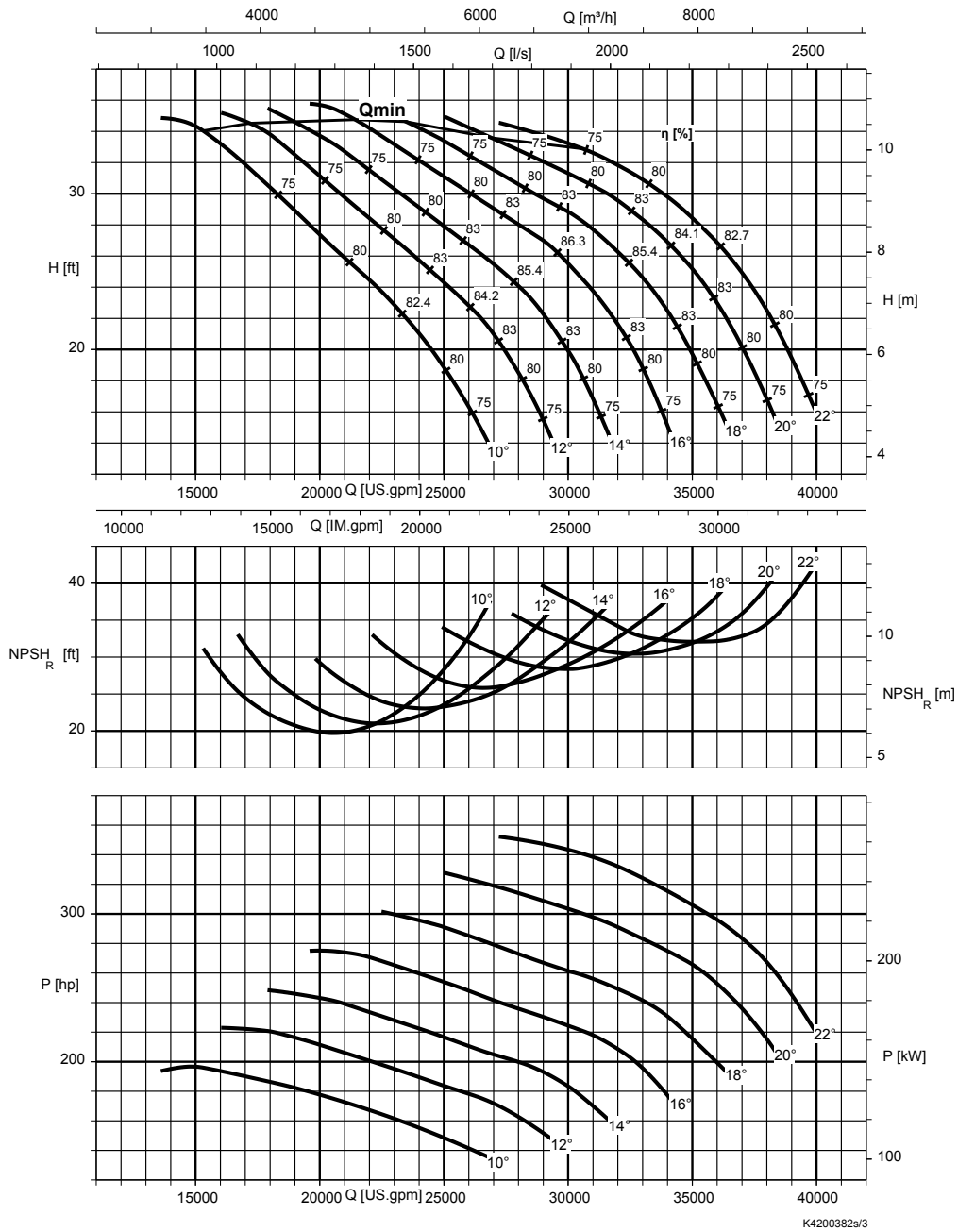

### Free passage

Angle [°]	Free passage		Angle [°]	Free passage	
	[inch]	[mm]		[inch]	[mm]
22	6 5/8	170	14	5 1/8	130
20	6 1/4	160	12	4 3/4	120
18	5 7/8	150	10	4 3/8	110
16	5 1/2	140			

### Rated power P<sub>2</sub> and mass moment of inertia J<sup>37)</sup>

Size	Rated power P <sub>2</sub>				Mass moment of inertia J [kgm²]
	UTG		XTG		
	[hp]	[kW]	[hp]	[kW]	
PB4 1000-700 / 155 10	200	155	–	–	17.0
PB4 1000-700 / 200 10	270	200	–	–	18.7
PB4 1000-700 / 250 10	335	250	–	–	20.9

37) These values are valid for a density = 1 kg/dm<sup>3</sup> and a kinematic viscosity of up to 20 mm<sup>2</sup>/s.

n = 585 rpm

## Amacan PA4 1200-870, n = 585 rpm

Characteristic curves to ISO 9906 / 2 / 2B. n = rated speed

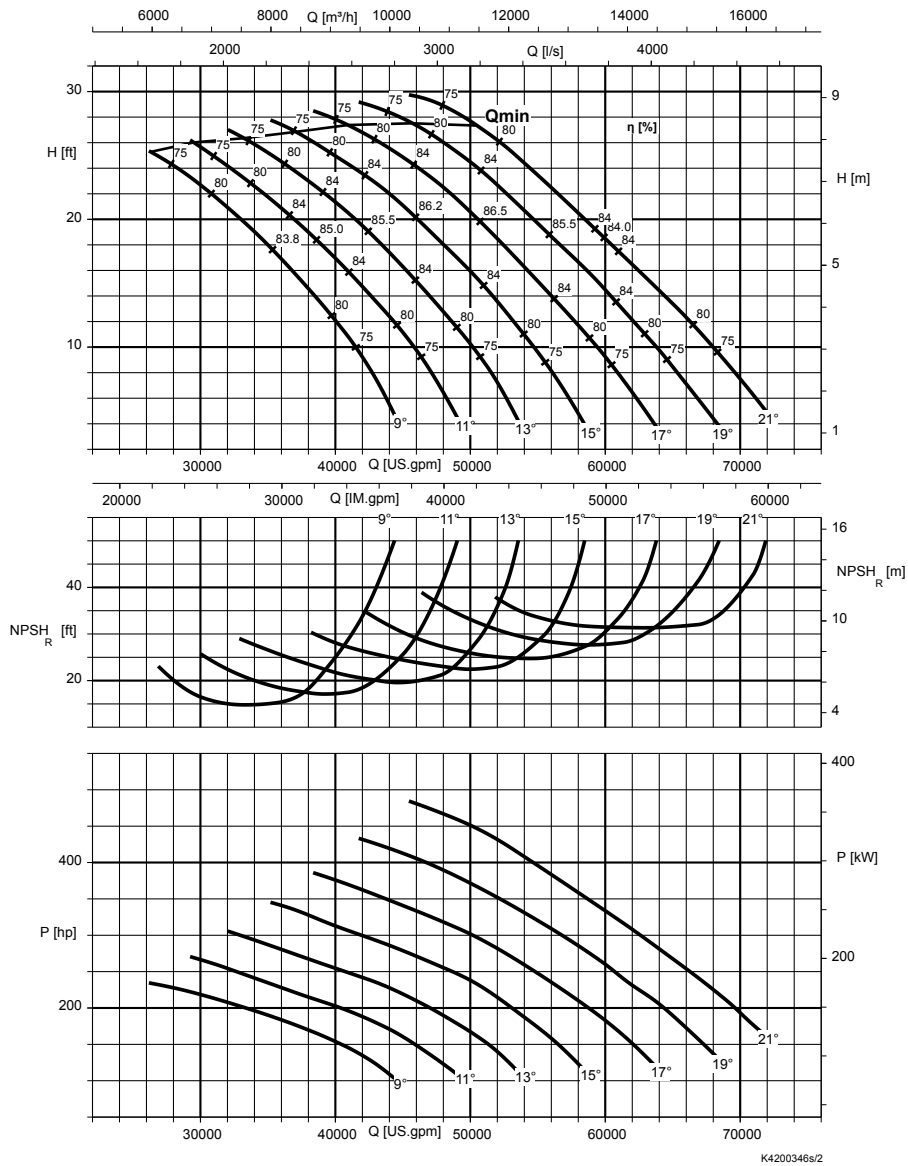

### Free passage

Angle [°]	Free passage		Angle [°]	Free passage	
	[inch]	[mm]		[inch]	[mm]
21	7 7/8	200	13	5 3/4	145
19	7 1/4	185	11	5 1/4	135
17	6 7/8	175	9	4 7/8	125
15	6 1/4	160			

### Rated power P<sub>2</sub> and mass moment of inertia J<sup>38)</sup>

Size	Rated power P <sub>2</sub>				Mass moment of inertia J [kgm <sup>2</sup> ]
	UTG		XTG		
	[hp]	[kW]	[hp]	[kW]	
PA4 1200-870 / 190 12	250	190	–	–	39.1
PA4 1200-870 / 251 12	335	250	–	–	45.0
PA4 1200-870 / 320 12	430	320	–	–	47.8
PA4 1200-870 / 370 12	500	370	–	–	50.5
PA4 1200-870 / 410 12	550	410	–	–	53.1

38) These values are valid for a density = 1 kg/dm<sup>3</sup> and a kinematic viscosity of up to 20 mm<sup>2</sup>/s.

## Amacan PB4 1200-870, n = 585 rpm

Characteristic curves to ISO 9906 / 2 / 2B. n = rated speed

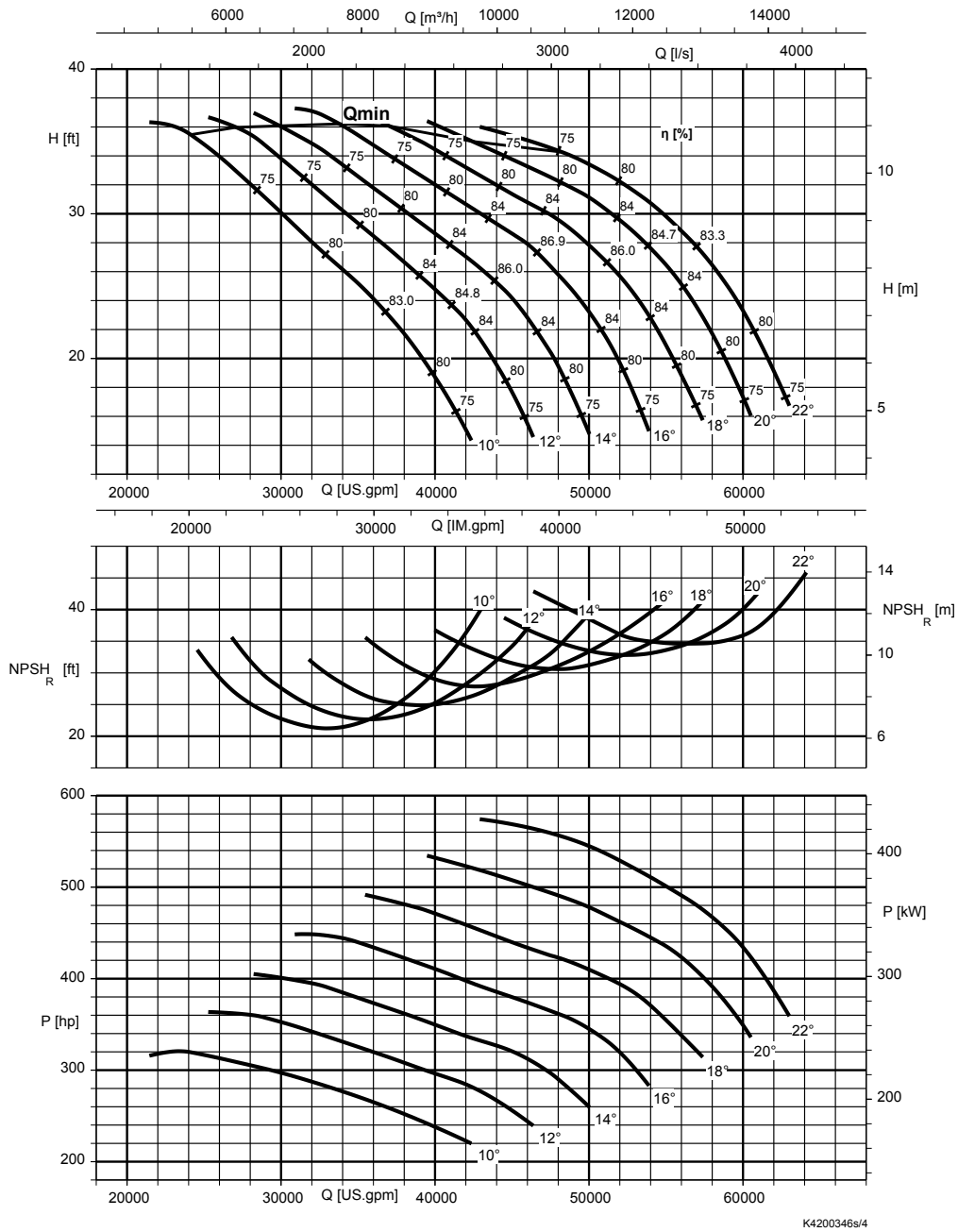

### Free passage

Angle [°]	Free passage		Angle [°]	Free passage	
	[inch]	[mm]		[inch]	[mm]
22	8 1/4	210	14	6 1/4	160
20	7 7/8	200	12	5 3/4	145
18	7 1/4	185	10	5 1/4	135
16	6 7/8	175			

### Rated power P<sub>2</sub> and mass moment of inertia J<sup>39)</sup>

Size	Rated power P <sub>2</sub>				Mass moment of inertia J [kgm <sup>2</sup> ]
	UTG		XTG		
	[hp]	[kW]	[hp]	[kW]	
PB4 1200-870 / 251 12	335	250	–	–	45.0
PB4 1200-870 / 320 12	430	320	–	–	47.8
PB4 1200-870 / 370 12	500	370	–	–	50.5
PB4 1200-870 / 410 12	550	410	–	–	53.1

39) These values are valid for a density = 1 kg/dm<sup>3</sup> and a kinematic viscosity of up to 20 mm<sup>2</sup>/s.

n = 500 rpm

## Amacan PA4 1500-1060, n = 500 rpm

Characteristic curves to ISO 9906 / 2 / 2B. n = rated speed

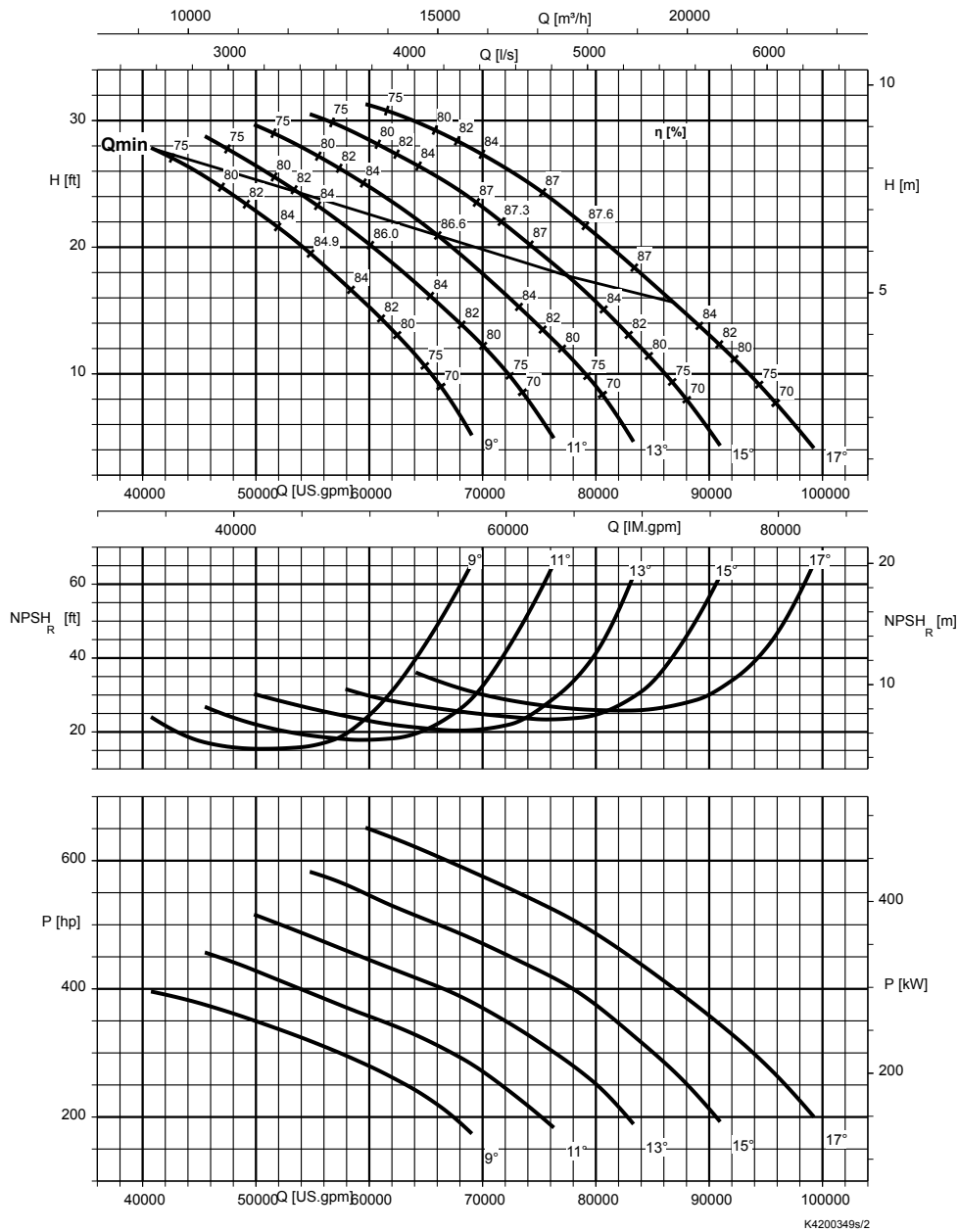

### Free passage

Angle [°]	Free passage		Angle [°]	Free passage	
	[inch]	[mm]		[inch]	[mm]
17	8 1/4	210	11	6 1/2	165
15	7 5/8	195	9	5 7/8	150
13	7	180			

### Rated power P<sub>2</sub> and mass moment of inertia J<sup>40)</sup>

Size	Rated power P <sub>2</sub>				Mass moment of inertia J
	UTG		XTG		
	[hp]	[kW]	[hp]	[kW]	[kgm <sup>2</sup> ]
PA 1500-1060 / 340 14	450	330	-	-	101,0

40) These values are valid for a density = 1 kg/dm<sup>3</sup> and a kinematic viscosity of up to 20 mm<sup>2</sup>/s.



### Amacan PA4 1600-1060, n = 500 rpm

Characteristic curves to ISO 9906 / 2 / 2B. n = rated speed

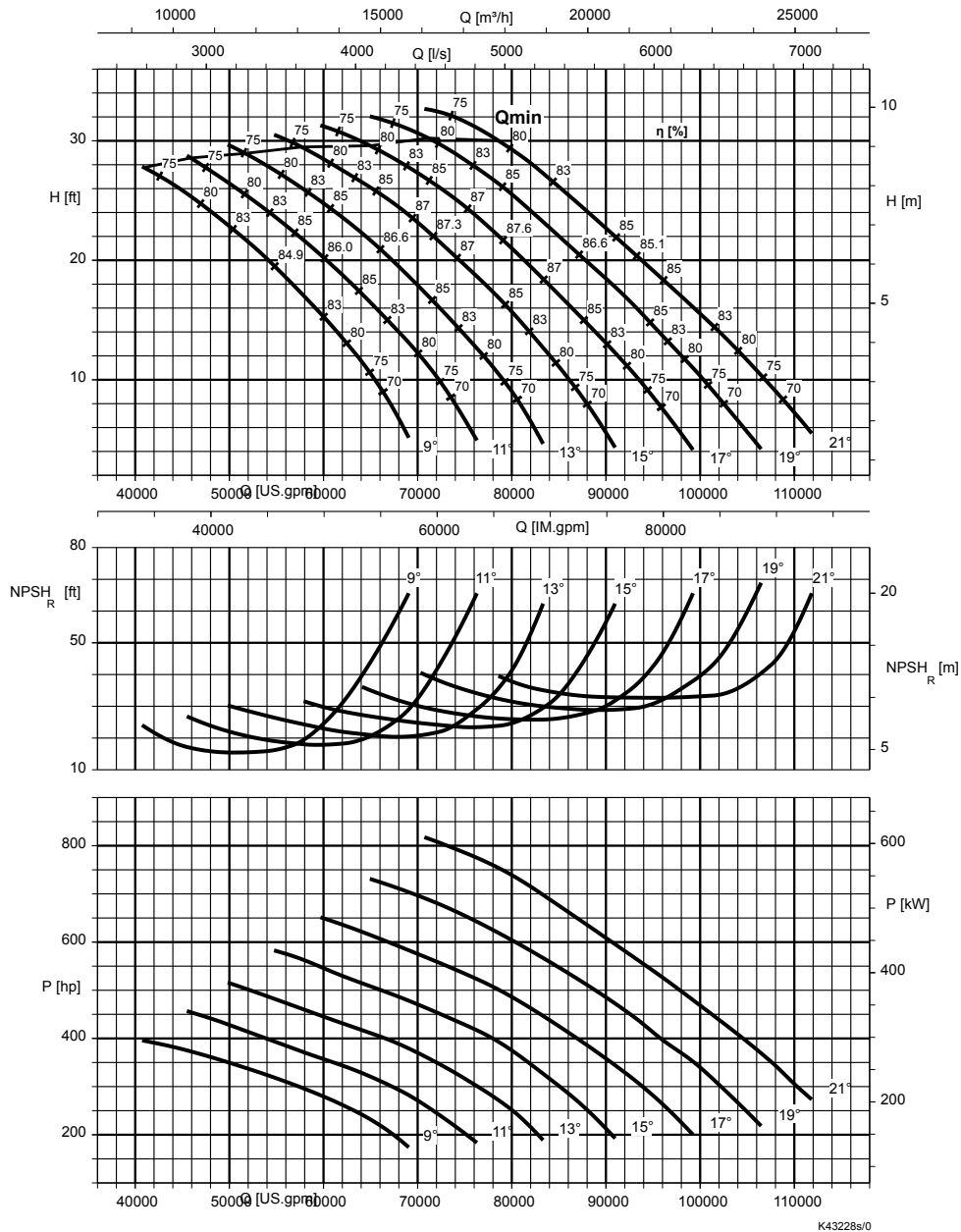

#### Free passage

Angle [°]	Free passage		Angle [°]	Free passage	
	[inch]	[mm]		[inch]	[mm]
21	9 1/2	240	13	7	180
19	8 7/8	225	11	6 1/2	165
17	8 1/4	210	9	5 7/8	150
15	7 5/8	195			

#### Rated power P<sub>2</sub> and mass moment of inertia J<sup>41)</sup>

Size	Rated power P <sub>2</sub>				Mass moment of inertia J
	UTG		XTG		
	[hp]	[kW]	[hp]	[kW]	[kgm²]
PA4 1600-1060 / 370 14	500	370	-	-	117,3
PA4 1600-1060 / 410 14	550	410	-	-	122,8
PA4 1600-1060 / 450 14	600	450	-	-	128,4
PA4 1600-1060 / 500 14	675	500	-	-	133,8
PA4 1600-1060 / 550 14	725	550	-	-	139,3

41) These values are valid for a density = 1 kg/dm<sup>3</sup> and a kinematic viscosity of up to 20 mm<sup>2</sup>/s.

## Amacan PB4 1600-1060, n = 500 rpm

Characteristic curves to ISO 9906 / 2 / 2B. n = rated speed

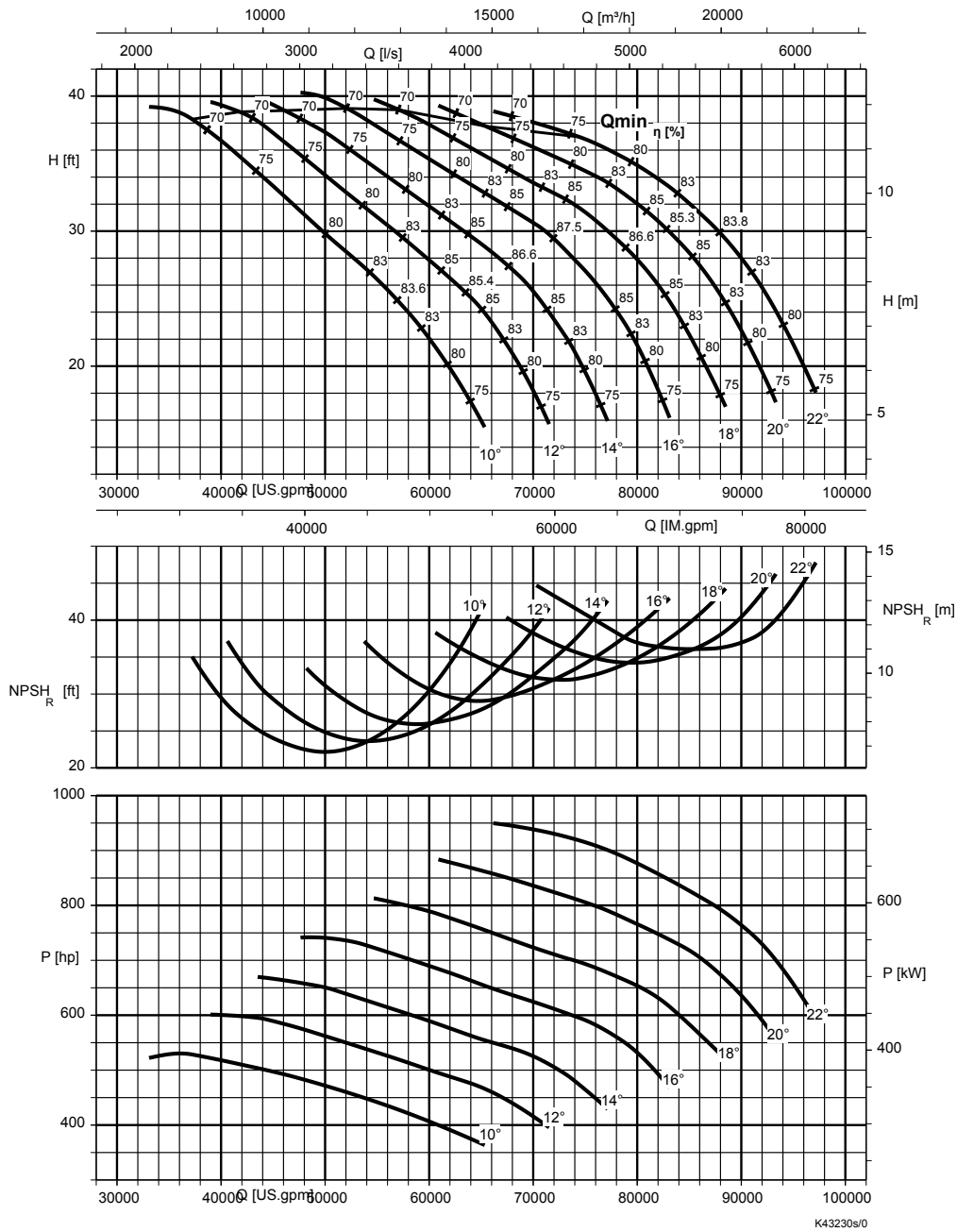

### Free passage

Angle [°]	Free passage		Angle [°]	Free passage	
	[inch]	[mm]		[inch]	[mm]
22	10	255	14	7 5/8	195
20	9 1/2	240	12	7	180
18	8 7/8	225	10	6 1/2	165
16	8 1/4	210			

### Rated power P<sub>2</sub> and mass moment of inertia J<sup>42)</sup>

Size	Rated power P <sub>2</sub>				Mass moment of inertia J
	UTG		XTG		
	[hp]	[kW]	[hp]	[kW]	[kgm²]
PB4 1600-1060 / 410 14	550	410	-	-	122,8
PB4 1600-1060 / 450 14	600	450	-	-	128,4
PB4 1600-1060 / 500 14	675	500	-	-	133,8
PB4 1600-1060 / 550 14	725	550	-	-	139,3

42) These values are valid for a density = 1 kg/dm<sup>3</sup> and a kinematic viscosity of up to 20 mm<sup>2</sup>/s.

Dimensions

UAG motors (500-270 to 600-350) [inch]

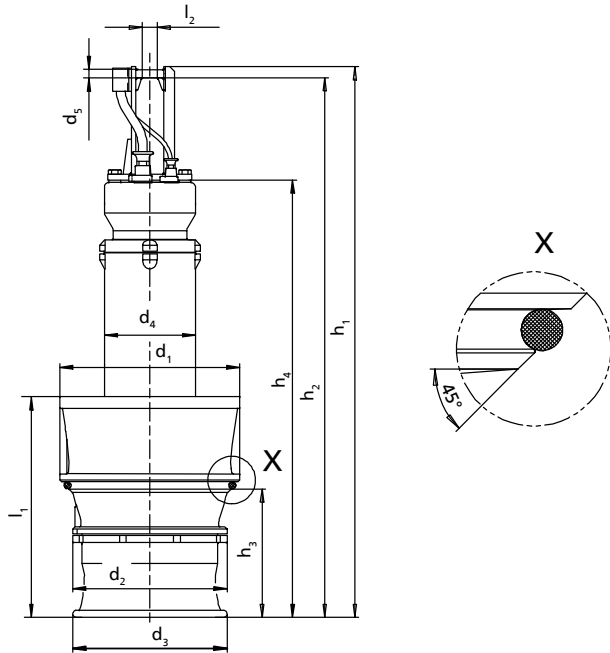

Dimensions of the pump set

Dimensions of the pump set [inch]

Size	Motor size	Poles	$d_1$	$d_2$	$d_3$	$d_4$	$d_5$	$h_1$	$h_2$	$h_3$	$h_4$	$l_1$	$l_2$	[lbs] <sup>43)</sup>
A 500-270	16	4	18 1/2	14 15/16	14 15/16	11	1 3/16	61	59 1/16	12	45 1/4	19 11/16	2 3/4	805
A 500-270	20	4	18 1/2	14 15/16	14 15/16	11	1 3/16	67 5/16	65 3/8	12	51 9/16	19 11/16	2 3/4	895
A 500-270	32	4	18 1/2	14 15/16	14 15/16	11	1 3/16	67 5/16	65 3/8	12	51 9/16	19 11/16	2 3/4	980
A 500-270	40	4	18 1/2	14 15/16	14 15/16	11	1 3/16	67 5/16	65 3/8	12	51 9/16	19 11/16	2 3/4	995
A 500-270	6	6	18 1/2	14 15/16	14 15/16	11	1 3/16	61	59 1/16	12	45 1/4	19 11/16	2 3/4	785
A 500-270	10	6	18 1/2	14 15/16	14 15/16	11	1 3/16	61	59 1/16	12	45 1/4	19 11/16	2 3/4	785
A 500-270	6	8	18 1/2	14 15/16	14 15/16	11	1 3/16	67 5/16	65 3/8	12	51 9/16	19 11/16	2 3/4	870
A 600-350	16	6	22 7/16	19 1/8	19 1/8	11	1 3/16	65 9/16	63 9/16	21 7/8	49 13/16	32 5/16	2 3/4	1060
A 600-350	25	6	22 7/16	19 1/8	19 1/8	11	1 3/16	71 7/8	69 7/8	21 7/8	56 1/8	32 5/16	2 3/4	1170
A 600-350	40	6	22 7/16	19 1/8	19 1/8	11	1 3/16	79 1/8	77 3/16	21 7/8	63 3/8	32 5/16	2 3/4	1325
A 600-350	6	8	22 7/16	19 1/8	19 1/8	11	1 3/16	71 7/8	69 7/8	21 7/8	56 1/8	32 5/16	2 3/4	1100
A 600-350	10	8	22 7/16	19 1/8	19 1/8	11	1 3/16	71 7/8	69 7/8	21 7/8	56 1/8	32 5/16	2 3/4	1100
A 600-350	18	8	22 7/16	19 1/8	19 1/8	11	1 3/16	71 7/8	69 7/8	21 7/8	56 1/8	32 5/16	2 3/4	1145
B 600-350	25	6	22 7/16	19 1/8	19 1/8	11	1 3/16	71 7/8	69 7/8	21 7/8	56 1/8	32 5/16	2 3/4	1205
B 600-350	40	6	22 7/16	19 1/8	19 1/8	11	1 3/16	79 1/8	77 3/16	21 7/8	63 3/8	32 5/16	2 3/4	1360

43) Pump set with 33 ft [10 m] power cable (460 V) and 16.4 ft [5 m] support rope

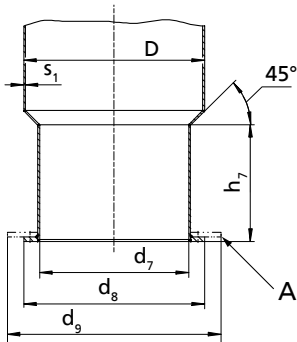

Dimensions of the discharge tube

A	Suction umbrella; option for reducing the minimum water level
---	---

Dimensions of the discharge tube [inch]

Size	Motor size	Poles	D	d <sub>7</sub>	d <sub>8</sub>	d <sub>9</sub>	h <sub>7</sub>	s <sub>1</sub>
A 500-270	16	4	20	15 <sup>3</sup> / <sub>4</sub>	19 <sup>7</sup> / <sub>8</sub>	25 <sup>9</sup> / <sub>16</sub>	11 <sup>5</sup> / <sub>8</sub>	<sup>1</sup> / <sub>4</sub>
A 500-270	20	4	20	15 <sup>3</sup> / <sub>4</sub>	19 <sup>7</sup> / <sub>8</sub>	25 <sup>9</sup> / <sub>16</sub>	11 <sup>5</sup> / <sub>8</sub>	<sup>1</sup> / <sub>4</sub>
A 500-270	32	4	20	15 <sup>3</sup> / <sub>4</sub>	19 <sup>7</sup> / <sub>8</sub>	25 <sup>9</sup> / <sub>16</sub>	11 <sup>5</sup> / <sub>8</sub>	<sup>1</sup> / <sub>4</sub>
A 500-270	40	4	20	15 <sup>3</sup> / <sub>4</sub>	19 <sup>7</sup> / <sub>8</sub>	25 <sup>9</sup> / <sub>16</sub>	11 <sup>5</sup> / <sub>8</sub>	<sup>1</sup> / <sub>4</sub>
A 500-270	6	6	20	15 <sup>3</sup> / <sub>4</sub>	19 <sup>7</sup> / <sub>8</sub>	25 <sup>9</sup> / <sub>16</sub>	11 <sup>5</sup> / <sub>8</sub>	<sup>1</sup> / <sub>4</sub>
A 500-270	10	6	20	15 <sup>3</sup> / <sub>4</sub>	19 <sup>7</sup> / <sub>8</sub>	25 <sup>9</sup> / <sub>16</sub>	11 <sup>5</sup> / <sub>8</sub>	<sup>1</sup> / <sub>4</sub>
A 500-270	6	8	20	15 <sup>3</sup> / <sub>4</sub>	19 <sup>7</sup> / <sub>8</sub>	25 <sup>9</sup> / <sub>16</sub>	11 <sup>5</sup> / <sub>8</sub>	<sup>1</sup> / <sub>4</sub>
A 600-350	16	6	24	19 <sup>11</sup> / <sub>16</sub>	24	35 <sup>7</sup> / <sub>16</sub>	21 <sup>1</sup> / <sub>4</sub>	<sup>1</sup> / <sub>4</sub>
A 600-350	25	6	24	19 <sup>11</sup> / <sub>16</sub>	24	35 <sup>7</sup> / <sub>16</sub>	21 <sup>1</sup> / <sub>4</sub>	<sup>1</sup> / <sub>4</sub>
A 600-350	40	6	24	19 <sup>11</sup> / <sub>16</sub>	24	35 <sup>7</sup> / <sub>16</sub>	21 <sup>1</sup> / <sub>4</sub>	<sup>1</sup> / <sub>4</sub>
A 600-350	6	8	24	19 <sup>11</sup> / <sub>16</sub>	24	35 <sup>7</sup> / <sub>16</sub>	21 <sup>1</sup> / <sub>4</sub>	<sup>1</sup> / <sub>4</sub>
A 600-350	10	8	24	19 <sup>11</sup> / <sub>16</sub>	24	35 <sup>7</sup> / <sub>16</sub>	21 <sup>1</sup> / <sub>4</sub>	<sup>1</sup> / <sub>4</sub>
A 600-350	18	8	24	19 <sup>11</sup> / <sub>16</sub>	24	35 <sup>7</sup> / <sub>16</sub>	21 <sup>1</sup> / <sub>4</sub>	<sup>1</sup> / <sub>4</sub>
B 600-350	25	6	24	19 <sup>11</sup> / <sub>16</sub>	24	35 <sup>7</sup> / <sub>16</sub>	21 <sup>1</sup> / <sub>4</sub>	<sup>1</sup> / <sub>4</sub>
B 600-350	40	6	24	19 <sup>11</sup> / <sub>16</sub>	24	35 <sup>7</sup> / <sub>16</sub>	21 <sup>1</sup> / <sub>4</sub>	<sup>1</sup> / <sub>4</sub>

UTG/XTG motors (700-470 to 1600-1060) [inch]

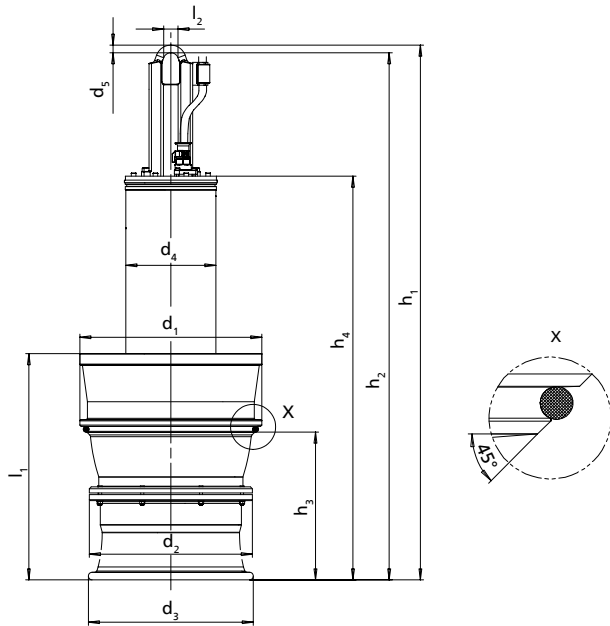

Dimensions of the pump set

Dimensions of the pump set [inch]

Size	Motor size	Poles	d <sub>1</sub>	d <sub>2</sub>	d <sub>3</sub>	d <sub>4</sub>	d <sub>5</sub>	h <sub>1</sub>	h <sub>2</sub>	h <sub>3</sub>	h <sub>4</sub>	l <sub>1</sub>	l <sub>2</sub>	[lbs] <sup>44)</sup>
A 700 - 470	80	6	26 9/16	23 1/16	23 1/16	15 3/16	1 9/16	94 1/8	92 1/2	16 15/16	66 15/16	28 15/16	3 1/8	2240
A 700 - 470	100	6	26 9/16	23 1/16	23 1/16	15 3/16	1 9/16	94 1/8	92 1/2	16 15/16	66 15/16	28 15/16	3 1/8	2360
A 700 - 470	120	6	26 9/16	23 1/16	23 1/16	15 3/16	1 9/16	94 1/8	92 1/2	16 15/16	66 15/16	28 15/16	3 1/8	2515
A 700 - 470	30	8	26 9/16	23 1/16	23 1/16	15 3/16	1 9/16	86 1/4	84 5/8	16 15/16	59 1/16	28 15/16	3 1/8	1995
A 700 - 470	40	8	26 9/16	23 1/16	23 1/16	15 3/16	1 9/16	86 1/4	84 5/8	16 15/16	59 1/16	28 15/16	3 1/8	2010
A 700 - 470	55	8	26 9/16	23 1/16	23 1/16	15 3/16	1 9/16	94 1/8	92 1/2	16 15/16	66 15/16	28 15/16	3 1/8	2250
A 700 - 470	70	8	26 9/16	23 1/16	23 1/16	15 3/16	1 9/16	94 1/8	92 1/2	16 15/16	66 15/16	28 15/16	3 1/8	2275
B 700 - 470	100	6	26 9/16	23 1/16	23 1/16	15 3/16	1 9/16	94 1/8	92 1/2	16 15/16	66 15/16	28 15/16	3 1/8	2425
B 700 - 470	120	6	26 9/16	23 1/16	23 1/16	15 3/16	1 9/16	94 1/8	92 1/2	16 15/16	66 15/16	28 15/16	3 1/8	2580
B 700 - 470	40	8	26 9/16	23 1/16	23 1/16	15 3/16	1 9/16	86 1/4	84 5/8	16 15/16	59 1/16	28 15/16	3 1/8	2075
B 700 - 470	55	8	26 9/16	23 1/16	23 1/16	15 3/16	1 9/16	94 1/8	92 1/2	16 15/16	66 15/16	28 15/16	3 1/8	2305
B 700 - 470	70	8	26 9/16	23 1/16	23 1/16	15 3/16	1 9/16	94 1/8	92 1/2	16 15/16	66 15/16	28 15/16	3 1/8	2340
B 700 - 470	100	8	26 9/16	23 1/16	23 1/16	15 3/16	1 9/16	94 1/8	92 1/2	16 15/16	66 15/16	28 15/16	3 1/8	2580
A 800 - 540	55	8	30 5/16	26	26	15 3/16	1 9/16	96 1/4	94 11/16	21 5/8	69 1/8	37 3/16	3 1/8	2570
A 800 - 540	70	8	30 5/16	26	26	15 3/16	1 9/16	96 1/4	94 11/16	21 5/8	69 1/8	37 3/16	3 1/8	2590
A 800 - 540	100	8	30 5/16	26	26	15 3/16	1 9/16	96 1/4	94 11/16	21 5/8	69 1/8	37 3/16	3 1/8	2845
B 800 - 540	70	8	30 5/16	26	26	15 3/16	1 9/16	96 1/4	94 11/16	21 5/8	69 1/8	37 3/16	3 1/8	2660
B 800 - 540	100	8	30 5/16	26	26	15 3/16	1 9/16	96 1/4	94 11/16	21 5/8	69 1/8	37 3/16	3 1/8	2900
A 900 - 540	120	8	33 7/8	26	26	18 11/16	1 9/16	102 15/16	101 3/8	22 7/16	75 13/16	41 1/8	3 1/8	3430
A 900 - 540	40	10	33 7/8	26	26	18 11/16	1 9/16	102 15/16	101 3/8	22 7/16	75 13/16	41 1/8	3 1/8	3255
A 900 - 540	60	10	33 7/8	26	26	18 11/16	1 9/16	102 15/16	101 3/8	22 7/16	75 13/16	41 1/8	3 1/8	3265
A 900 - 540	90	10	33 7/8	26	26	18 11/16	1 9/16	102 15/16	101 3/8	22 7/16	75 13/16	41 1/8	3 1/8	3275
B 900 - 540	120	8	33 7/8	26	26	18 11/16	1 9/16	102 15/16	101 3/8	22 7/16	75 13/16	41 1/8	3 1/8	3485
B 900 - 540	160	8	33 7/8	26	26	18 11/16	1 9/16	102 15/16	101 3/8	22 7/16	75 13/16	41 1/8	3 1/8	3825
A 1000 - 700	120	10	37 13/16	33 7/8	34 1/4	18 11/16	1 9/16	111	109 7/16	30 11/16	83 7/8	47 1/16	3 1/8	4620
A 1000 - 700	155	10	37 13/16	33 7/8	34 1/4	21 7/8	1 15/16	127 3/16	124 13/16	30 11/16	103 9/16	47 1/16	3 9/16	6075
A 1000 - 700	200	10	37 13/16	33 7/8	34 1/4	21 7/8	1 15/16	127 3/16	124 13/16	30 11/16	103 9/16	47 1/16	3 9/16	6360
A 1000 - 700	250	10	37 13/16	33 7/8	34 1/4	21 7/8	1 15/16	127 3/16	124 13/16	30 11/16	103 9/16	47 1/16	3 9/16	6880
B 1000 - 700	155	10	37 13/16	33 7/8	34 1/4	21 7/8	1 15/16	127 3/16	124 13/16	30 11/16	103 9/16	47 1/16	3 9/16	6165

44) Pump set with 33 ft [10 m] power cable (460 V) and 16.4 ft [5 m] support rope

Size	Motor size	Poles	d <sub>1</sub>	d <sub>2</sub>	d <sub>3</sub>	d <sub>4</sub>	d <sub>5</sub>	h <sub>1</sub>	h <sub>2</sub>	h <sub>3</sub>	h <sub>4</sub>	l <sub>1</sub>	l <sub>2</sub>	[lbs] <sup>(44)</sup>
B 1000 - 700	200	10	37 13/16	33 7/8	34 1/4	21 7/8	1 15/16	127 3/16	124 13/16	30 11/16	103 9/16	47 1/16	3 9/16	6450
B 1000 - 700	250	10	37 13/16	33 7/8	34 1/4	21 7/8	1 15/16	127 3/16	124 13/16	30 11/16	103 9/16	47 1/16	3 9/16	6980
A 1200 - 870	190	12	45 1/4	41 5/16	41 5/16	21 7/8	1 15/16	129 1/2	127 3/16	39 15/16	105 7/8	55 5/16	3 9/16	7830
A 1200 - 870	251	12	45 1/4	41 5/16	41 5/16	25 9/16	2 3/8	147 1/4	144 5/16	39 15/16	119 11/16	55 5/16	3 9/16	9605
A 1200 - 870	320	12	45 1/4	41 5/16	41 5/16	25 9/16	2 3/8	156 1/8	153 1/8	39 15/16	128 9/16	55 5/16	3 9/16	10630
A 1200 - 870	370	12	45 1/4	41 5/16	41 5/16	25 9/16	2 3/8	156 1/8	153 1/8	39 15/16	128 9/16	55 5/16	3 9/16	10980
A 1200 - 870	410	12	45 1/4	41 5/16	41 5/16	25 9/16	2 3/8	156 1/8	153 1/8	39 15/16	128 9/16	55 5/16	3 9/16	11365
B 1200 - 870	251	12	45 1/4	41 5/16	41 5/16	25 9/16	2 3/8	147 1/4	144 5/16	39 15/16	119 11/16	55 5/16	3 9/16	9880
B 1200 - 870	320	12	45 1/4	41 5/16	41 5/16	25 9/16	2 3/8	156 1/8	153 1/8	39 15/16	128 9/16	55 5/16	3 9/16	10695
B 1200 - 870	370	12	45 1/4	41 5/16	41 5/16	25 9/16	2 3/8	156 1/8	153 1/8	39 15/16	128 9/16	55 5/16	3 9/16	11265
B 1200 - 870	410	12	45 1/4	41 5/16	41 5/16	25 9/16	2 3/8	156 1/8	153 1/8	39 15/16	128 9/16	55 5/16	3 9/16	11665
A 1500-1060	340	14	56 5/16	51 3/16	51 3/16	25 9/16	2 3/8	157 1/2	154 1/2	58 1/16	131 1/8	73 1/4	3 9/16	13160
A 1600-1060	370	14	60 5/8	53 1/8	51 3/16	29 15/16	2 3/4	160 13/16	157 5/16	49 5/8	132 7/8	70 7/8	3 15/16	15540
A 1600-1060	410	14	60 5/8	53 1/8	51 3/16	29 15/16	2 3/4	160 13/16	157 5/16	49 5/8	132 7/8	70 7/8	3 15/16	16250
A 1600-1060	450	14	60 5/8	53 1/8	51 3/16	30 1/2	2 3/4	172 5/8	168 11/16	49 5/8	144 11/16	70 7/8	3 15/16	17615
A 1600-1060	500	14	60 5/8	53 1/8	51 3/16	30 1/2	2 3/4	172 5/8	168 11/16	49 5/8	144 11/16	70 7/8	3 15/16	18210
A 1600-1060	550	14	60 5/8	53 1/8	51 3/16	30 1/2	2 3/4	172 5/8	168 11/16	49 5/8	144 11/16	70 7/8	3 15/16	18695
B 1600-1060	410	14	60 5/8	53 1/8	51 3/16	29 15/16	2 3/4	160 13/16	157 5/16	49 5/8	132 7/8	70 7/8	3 15/16	16645
B 1600-1060	450	14	60 5/8	53 1/8	51 3/16	30 1/2	2 3/4	172 5/8	168 11/16	49 5/8	144 11/16	70 7/8	3 15/16	18010
B 1600-1060	500	14	60 5/8	53 1/8	51 3/16	30 1/2	2 3/4	172 5/8	168 11/16	49 5/8	144 11/16	70 7/8	3 15/16	18605
B 1600-1060	550	14	60 5/8	53 1/8	51 3/16	30 1/2	2 3/4	172 5/8	168 11/16	49 5/8	144 11/16	70 7/8	3 15/16	19090

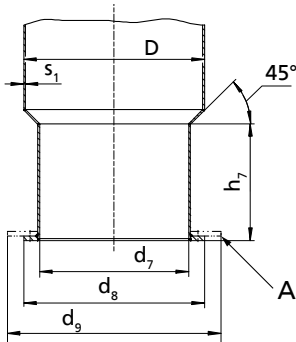

Dimensions of the discharge tube

A	Suction umbrella; option for reducing the minimum water level
---	---

Dimensions of the discharge tube [inch]

Size	Motor size	Poles	D	d <sub>7</sub>	d <sub>8</sub>	d <sub>9</sub>	h <sub>7</sub>	s <sub>1</sub>
A 700 - 470	80	6	28	23 5/8	27 15/16	43 5/16	16 9/16	5/16
A 700 - 470	100	6	28	23 5/8	27 15/16	43 5/16	16 9/16	5/16
A 700 - 470	120	6	28	23 5/8	27 15/16	43 5/16	16 9/16	5/16
A 700 - 470	30	8	28	23 5/8	27 15/16	43 5/16	16 9/16	5/16
A 700 - 470	40	8	28	23 5/8	27 15/16	43 5/16	16 9/16	5/16
A 700 - 470	55	8	28	23 5/8	27 15/16	43 5/16	16 9/16	5/16
A 700 - 470	70	8	28	23 5/8	27 15/16	43 5/16	16 9/16	5/16
B 700 - 470	100	6	28	23 5/8	27 15/16	43 5/16	16 9/16	5/16
B 700 - 470	120	6	28	23 5/8	27 15/16	43 5/16	16 9/16	5/16
B 700 - 470	40	8	28	23 5/8	27 15/16	43 5/16	16 9/16	5/16
B 700 - 470	55	8	28	23 5/8	27 15/16	43 5/16	16 9/16	5/16
B 700 - 470	70	8	28	23 5/8	27 15/16	43 5/16	16 9/16	5/16
B 700 - 470	100	8	28	23 5/8	27 15/16	43 5/16	16 9/16	5/16
A 800 - 540	55	8	32	26 3/4	31 7/8	49 3/16	20 11/16	5/16

<sup>44)</sup> Pump set with 33 ft [10 m] power cable (460 V) and 16.4 ft [5 m] support rope

Size	Motor size	Poles	D	d <sub>7</sub>	d <sub>8</sub>	d <sub>9</sub>	h <sub>7</sub>	s <sub>1</sub>
A 800 - 540	70	8	32	26 <sup>3</sup> / <sub>4</sub>	31 <sup>7</sup> / <sub>8</sub>	49 <sup>3</sup> / <sub>16</sub>	20 <sup>11</sup> / <sub>16</sub>	<sup>5</sup> / <sub>16</sub>
B 800 - 540	100	8	32	26 <sup>3</sup> / <sub>4</sub>	31 <sup>7</sup> / <sub>8</sub>	49 <sup>3</sup> / <sub>16</sub>	20 <sup>11</sup> / <sub>16</sub>	<sup>5</sup> / <sub>16</sub>
B 800 - 540	70	8	32	26 <sup>3</sup> / <sub>4</sub>	31 <sup>7</sup> / <sub>8</sub>	49 <sup>3</sup> / <sub>16</sub>	20 <sup>11</sup> / <sub>16</sub>	<sup>5</sup> / <sub>16</sub>
B 800 - 540	100	8	32	26 <sup>3</sup> / <sub>4</sub>	31 <sup>7</sup> / <sub>8</sub>	49 <sup>3</sup> / <sub>16</sub>	20 <sup>11</sup> / <sub>16</sub>	<sup>5</sup> / <sub>16</sub>
A 900 - 540	120	8	36	27 <sup>9</sup> / <sub>16</sub>	35 <sup>13</sup> / <sub>16</sub>	49 <sup>3</sup> / <sub>16</sub>	20 <sup>1</sup> / <sub>4</sub>	<sup>5</sup> / <sub>16</sub>
A 900 - 540	40	10	36	27 <sup>9</sup> / <sub>16</sub>	35 <sup>13</sup> / <sub>16</sub>	49 <sup>3</sup> / <sub>16</sub>	20 <sup>1</sup> / <sub>4</sub>	<sup>5</sup> / <sub>16</sub>
A 900 - 540	60	10	36	27 <sup>9</sup> / <sub>16</sub>	35 <sup>13</sup> / <sub>16</sub>	49 <sup>3</sup> / <sub>16</sub>	20 <sup>1</sup> / <sub>4</sub>	<sup>5</sup> / <sub>16</sub>
A 900 - 540	90	10	36	27 <sup>9</sup> / <sub>16</sub>	35 <sup>13</sup> / <sub>16</sub>	49 <sup>3</sup> / <sub>16</sub>	20 <sup>1</sup> / <sub>4</sub>	<sup>5</sup> / <sub>16</sub>
B 900 - 540	120	8	36	27 <sup>9</sup> / <sub>16</sub>	35 <sup>13</sup> / <sub>16</sub>	49 <sup>3</sup> / <sub>16</sub>	20 <sup>1</sup> / <sub>4</sub>	<sup>5</sup> / <sub>16</sub>
B 900 - 540	160	8	36	27 <sup>9</sup> / <sub>16</sub>	35 <sup>13</sup> / <sub>16</sub>	49 <sup>3</sup> / <sub>16</sub>	20 <sup>1</sup> / <sub>4</sub>	<sup>5</sup> / <sub>16</sub>
A 1000 - 700	120	10	40	34 <sup>5</sup> / <sub>8</sub>	39 <sup>15</sup> / <sub>16</sub>	63	30 <sup>1</sup> / <sub>8</sub>	<sup>3</sup> / <sub>8</sub>
A 1000 - 700	155	10	40	34 <sup>5</sup> / <sub>8</sub>	39 <sup>15</sup> / <sub>16</sub>	63	30 <sup>1</sup> / <sub>8</sub>	<sup>3</sup> / <sub>8</sub>
A 1000 - 700	200	10	40	34 <sup>5</sup> / <sub>8</sub>	39 <sup>15</sup> / <sub>16</sub>	63	30 <sup>1</sup> / <sub>8</sub>	<sup>3</sup> / <sub>8</sub>
A 1000 - 700	250	10	40	34 <sup>5</sup> / <sub>8</sub>	39 <sup>15</sup> / <sub>16</sub>	63	30 <sup>1</sup> / <sub>8</sub>	<sup>3</sup> / <sub>8</sub>
B 1000 - 700	155	10	40	34 <sup>5</sup> / <sub>8</sub>	39 <sup>15</sup> / <sub>16</sub>	63	30 <sup>1</sup> / <sub>8</sub>	<sup>3</sup> / <sub>8</sub>
B 1000 - 700	200	10	40	34 <sup>5</sup> / <sub>8</sub>	39 <sup>15</sup> / <sub>16</sub>	63	30 <sup>1</sup> / <sub>8</sub>	<sup>3</sup> / <sub>8</sub>
B 1000 - 700	250	10	40	34 <sup>5</sup> / <sub>8</sub>	39 <sup>15</sup> / <sub>16</sub>	63	30 <sup>1</sup> / <sub>8</sub>	<sup>3</sup> / <sub>8</sub>
A 1200 - 870	190	12	48 <sup>1</sup> / <sub>16</sub>	42 <sup>1</sup> / <sub>8</sub>	48 <sup>1</sup> / <sub>16</sub>	78 <sup>3</sup> / <sub>4</sub>	39 <sup>3</sup> / <sub>8</sub>	<sup>1</sup> / <sub>2</sub>
A 1200 - 870	251	12	48 <sup>1</sup> / <sub>16</sub>	42 <sup>1</sup> / <sub>8</sub>	48 <sup>1</sup> / <sub>16</sub>	78 <sup>3</sup> / <sub>4</sub>	39 <sup>3</sup> / <sub>8</sub>	<sup>1</sup> / <sub>2</sub>
A 1200 - 870	320	12	48 <sup>1</sup> / <sub>16</sub>	42 <sup>1</sup> / <sub>8</sub>	48 <sup>1</sup> / <sub>16</sub>	78 <sup>3</sup> / <sub>4</sub>	39 <sup>3</sup> / <sub>8</sub>	<sup>1</sup> / <sub>2</sub>
A 1200 - 870	370	12	48 <sup>1</sup> / <sub>16</sub>	42 <sup>1</sup> / <sub>8</sub>	48 <sup>1</sup> / <sub>16</sub>	78 <sup>3</sup> / <sub>4</sub>	39 <sup>3</sup> / <sub>8</sub>	<sup>1</sup> / <sub>2</sub>
A 1200 - 870	410	12	48 <sup>1</sup> / <sub>16</sub>	42 <sup>1</sup> / <sub>8</sub>	48 <sup>1</sup> / <sub>16</sub>	78 <sup>3</sup> / <sub>4</sub>	39 <sup>3</sup> / <sub>8</sub>	<sup>1</sup> / <sub>2</sub>
B 1200 - 870	251	12	48 <sup>1</sup> / <sub>16</sub>	42 <sup>1</sup> / <sub>8</sub>	48 <sup>1</sup> / <sub>16</sub>	78 <sup>3</sup> / <sub>4</sub>	39 <sup>3</sup> / <sub>8</sub>	<sup>1</sup> / <sub>2</sub>
B 1200 - 870	320	12	48 <sup>1</sup> / <sub>16</sub>	42 <sup>1</sup> / <sub>8</sub>	48 <sup>1</sup> / <sub>16</sub>	78 <sup>3</sup> / <sub>4</sub>	39 <sup>3</sup> / <sub>8</sub>	<sup>1</sup> / <sub>2</sub>
B 1200 - 870	370	12	48 <sup>1</sup> / <sub>16</sub>	42 <sup>1</sup> / <sub>8</sub>	48 <sup>1</sup> / <sub>16</sub>	78 <sup>3</sup> / <sub>4</sub>	39 <sup>3</sup> / <sub>8</sub>	<sup>1</sup> / <sub>2</sub>
B 1200 - 870	410	12	48 <sup>1</sup> / <sub>16</sub>	42 <sup>1</sup> / <sub>8</sub>	48 <sup>1</sup> / <sub>16</sub>	78 <sup>3</sup> / <sub>4</sub>	39 <sup>3</sup> / <sub>8</sub>	<sup>1</sup> / <sub>2</sub>
A 1500-1060	340	14	60 <sup>1</sup> / <sub>16</sub>	52 <sup>3</sup> / <sub>8</sub>	59 <sup>13</sup> / <sub>16</sub>	96 <sup>7</sup> / <sub>16</sub>	57 <sup>1</sup> / <sub>2</sub>	<sup>1</sup> / <sub>2</sub>
A 1600-1060	370	14	64	55 <sup>7</sup> / <sub>8</sub>	63 <sup>3</sup> / <sub>4</sub>	96 <sup>7</sup> / <sub>16</sub>	48 <sup>7</sup> / <sub>16</sub>	<sup>1</sup> / <sub>2</sub>
A 1600-1060	410	14	64	55 <sup>7</sup> / <sub>8</sub>	63 <sup>3</sup> / <sub>4</sub>	96 <sup>7</sup> / <sub>16</sub>	48 <sup>7</sup> / <sub>16</sub>	<sup>1</sup> / <sub>2</sub>
A 1600-1060	450	14	64	55 <sup>7</sup> / <sub>8</sub>	63 <sup>3</sup> / <sub>4</sub>	96 <sup>7</sup> / <sub>16</sub>	48 <sup>7</sup> / <sub>16</sub>	<sup>1</sup> / <sub>2</sub>
A 1600-1060	500	14	64	55 <sup>7</sup> / <sub>8</sub>	63 <sup>3</sup> / <sub>4</sub>	96 <sup>7</sup> / <sub>16</sub>	48 <sup>7</sup> / <sub>16</sub>	<sup>1</sup> / <sub>2</sub>
A 1600-1060	550	14	64	55 <sup>7</sup> / <sub>8</sub>	63 <sup>3</sup> / <sub>4</sub>	96 <sup>7</sup> / <sub>16</sub>	48 <sup>7</sup> / <sub>16</sub>	<sup>1</sup> / <sub>2</sub>
B 1600-1060	410	14	64	55 <sup>7</sup> / <sub>8</sub>	63 <sup>3</sup> / <sub>4</sub>	96 <sup>7</sup> / <sub>16</sub>	48 <sup>7</sup> / <sub>16</sub>	<sup>1</sup> / <sub>2</sub>
B 1600-1060	450	14	64	55 <sup>7</sup> / <sub>8</sub>	63 <sup>3</sup> / <sub>4</sub>	96 <sup>7</sup> / <sub>16</sub>	48 <sup>7</sup> / <sub>16</sub>	<sup>1</sup> / <sub>2</sub>
B 1600-1060	500	14	64	55 <sup>7</sup> / <sub>8</sub>	63 <sup>3</sup> / <sub>4</sub>	96 <sup>7</sup> / <sub>16</sub>	48 <sup>7</sup> / <sub>16</sub>	<sup>1</sup> / <sub>2</sub>
B 1600-1060	550	14	64	55 <sup>7</sup> / <sub>8</sub>	63 <sup>3</sup> / <sub>4</sub>	96 <sup>7</sup> / <sub>16</sub>	48 <sup>7</sup> / <sub>16</sub>	<sup>1</sup> / <sub>2</sub>

UAG motors (500-270 to 600-350) [mm]

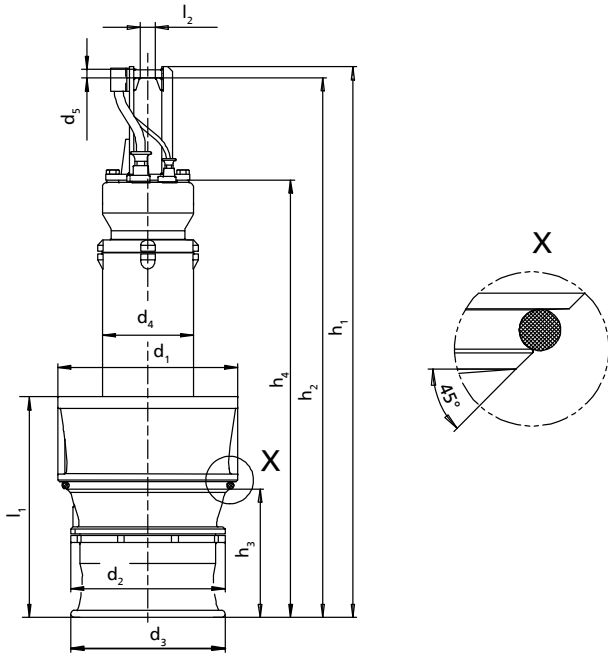

Dimensions of the pump set

Dimensions of the pump set [mm]

Size	Motor size	Poles	$d_1$	$d_2$	$d_3$	$d_4$	$d_5$	$h_1$	$h_2$	$h_3$	$h_4$	$l_1$	$l_2$	[kg] <sup>45)</sup>
A 500-270	16	4	470	380	380	280	30	1550	1500	305	1150	500	70	365
A 500-270	20	4	470	380	380	280	30	1710	1660	305	1310	500	70	405
A 500-270	32	4	470	380	380	280	30	1710	1660	305	1310	500	70	445
A 500-270	40	4	470	380	380	280	30	1710	1660	305	1310	500	70	450
A 500-270	6	6	470	380	380	280	30	1550	1500	305	1150	500	70	355
A 500-270	10	6	470	380	380	280	30	1550	1500	305	1150	500	70	355
A 500-270	6	8	470	380	380	280	30	1710	1660	305	1310	500	70	395
A 600-350	16	6	570	485	485	280	30	1665	1615	555	1265	820	70	480
A 600-350	25	6	570	485	485	280	30	1825	1775	555	1425	820	70	530
A 600-350	40	6	570	485	485	280	30	2010	1960	555	1610	820	70	600
A 600-350	6	8	570	485	485	280	30	1825	1775	555	1425	820	70	500
A 600-350	10	8	570	485	485	280	30	1825	1775	555	1425	820	70	500
A 600-350	18	8	570	485	485	280	30	1825	1775	555	1425	820	70	520
B 600-350	25	6	570	485	485	280	30	1825	1775	555	1425	820	70	545
B 600-350	40	6	570	485	485	280	30	2010	1960	555	1610	820	70	615

<sup>45)</sup> Pump set with 10 m power cable (400 V) and 5 m support rope



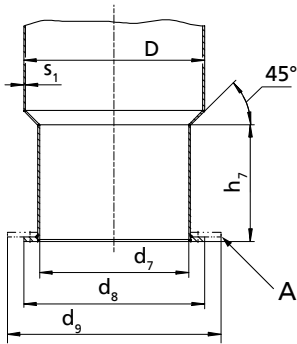

Dimensions of the discharge tube

A	Suction umbrella; option for reducing the minimum water level
---	---

Dimensions of the discharge tube [mm]

Size	Motor size	Poles	D	d <sub>7</sub>	d <sub>8</sub>	d <sub>9</sub>	h <sub>7</sub>	s <sub>1</sub>
A 500-270	16	4	508	400	505	650	295	7
A 500-270	20	4	508	400	505	650	295	7
A 500-270	32	4	508	400	505	650	295	7
A 500-270	40	4	508	400	505	650	295	7
A 500-270	6	6	508	400	505	650	295	7
A 500-270	10	6	508	400	505	650	295	7
A 500-270	6	8	508	400	505	650	295	7
A 600-350	16	6	610	500	610	900	540	7
A 600-350	25	6	610	500	610	900	540	7
A 600-350	40	6	610	500	610	900	540	7
A 600-350	6	8	610	500	610	900	540	7
A 600-350	10	8	610	500	610	900	540	7
A 600-350	18	8	610	500	610	900	540	7
B 600-350	25	6	610	500	610	900	540	7
B 600-350	40	6	610	500	610	900	540	7

UTG/XTG motors (700-470 to 1600-1060) [mm]

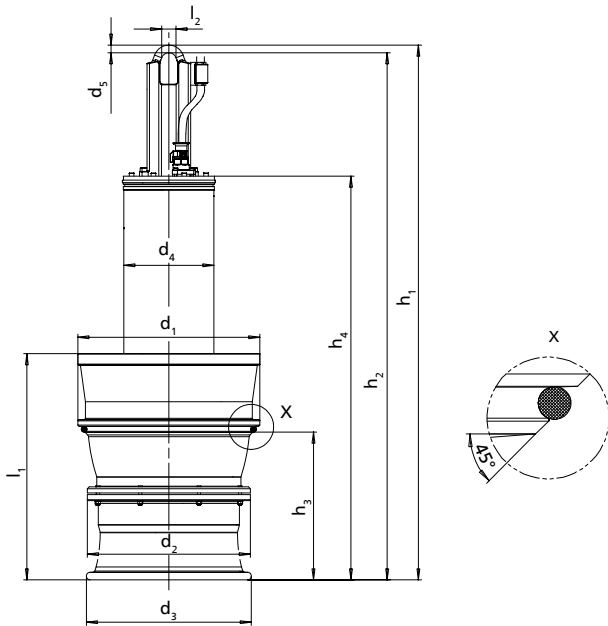

Dimensions of the pump set

Dimensions of the pump set

Size	Motor size	Poles	$d_1$	$d_2$	$d_3$	$d_4$	$d_5$	$h_1$	$h_2$	$h_3$	$h_4$	$l_1$	$l_2$	[kg] <sup>46)</sup>
A 700 - 470	80	6	675	585	585	385	40	2390	2350	430	1700	735	80	1015
A 700 - 470	100	6	675	585	585	385	40	2390	2350	430	1700	735	80	1070
A 700 - 470	120	6	675	585	585	385	40	2390	2350	430	1700	735	80	1140
A 700 - 470	30	8	675	585	585	385	40	2190	2150	430	1500	735	80	905
A 700 - 470	40	8	675	585	585	385	40	2190	2150	430	1500	735	80	910
A 700 - 470	55	8	675	585	585	385	40	2390	2350	430	1700	735	80	1020
A 700 - 470	70	8	675	585	585	385	40	2390	2350	430	1700	735	80	1030
B 700 - 470	100	6	675	585	585	385	40	2390	2350	430	1700	735	80	1100
B 700 - 470	120	6	675	585	585	385	40	2390	2350	430	1700	735	80	1170
B 700 - 470	40	8	675	585	585	385	40	2190	2150	430	1500	735	80	940
B 700 - 470	55	8	675	585	585	385	40	2390	2350	430	1700	735	80	1045
B 700 - 470	70	8	675	585	585	385	40	2390	2350	430	1700	735	80	1060
B 700 - 470	100	8	675	585	585	385	40	2390	2350	430	1700	735	80	1170
A 800 - 540	55	8	770	660	660	385	40	2445	2405	550	1755	945	80	1165
A 800 - 540	70	8	770	660	660	385	40	2445	2405	550	1755	945	80	1175
A 800 - 540	100	8	770	660	660	385	40	2445	2405	550	1755	945	80	1290
B 800 - 540	70	8	770	660	660	385	40	2445	2405	550	1755	945	80	1205
B 800 - 540	100	8	770	660	660	385	40	2445	2405	550	1755	945	80	1315
A 900 - 540	120	8	860	660	660	475	40	2615	2575	570	1925	1045	80	1555
A 900 - 540	40	10	860	660	660	475	40	2615	2575	570	1925	1045	80	1475
A 900 - 540	60	10	860	660	660	475	40	2615	2575	570	1925	1045	80	1480
A 900 - 540	90	10	860	660	660	475	40	2615	2575	570	1925	1045	80	1485
B 900 - 540	120	8	860	660	660	475	40	2615	2575	570	1925	1045	80	1580
B 900 - 540	160	8	860	660	660	475	40	2615	2575	570	1925	1045	80	1735
A 1000 - 700	120	10	960	860	870	475	40	2820	2780	780	2130	1195	80	2095
A 1000 - 700	155	10	960	860	870	555	50	3230	3170	780	2630	1195	90	2755
A 1000 - 700	200	10	960	860	870	555	50	3230	3170	780	2630	1195	90	2885
A 1000 - 700	250	10	960	860	870	555	50	3230	3170	780	2630	1195	90	3120
B 1000 - 700	155	10	960	860	870	555	50	3230	3170	780	2630	1195	90	2795
B 1000 - 700	200	10	960	860	870	555	50	3230	3170	780	2630	1195	90	2925
B 1000 - 700	250	10	960	860	870	555	50	3230	3170	780	2630	1195	90	3165
A 1200 - 870	190	12	1150	1050	1050	555	50	3290	3230	1015	2690	1405	90	3550
A 1200 - 870	251	12	1150	1050	1050	650	60	3740	3665	1015	3040	1405	90	4355

<sup>46)</sup> Pump set with 10 m power cable (400 V) and 5 m support rope

Size	Motor size	Poles	d <sub>1</sub>	d <sub>2</sub>	d <sub>3</sub>	d <sub>4</sub>	d <sub>5</sub>	h <sub>1</sub>	h <sub>2</sub>	h <sub>3</sub>	h <sub>4</sub>	l <sub>1</sub>	l <sub>2</sub>	[kg] <sup>46)</sup>
A 1200 - 870	320	12	1150	1050	1050	650	60	3965	3890	1015	3265	1405	90	4820
A 1200 - 870	370	12	1150	1050	1050	650	60	3965	3890	1015	3265	1405	90	4980
A 1200 - 870	410	12	1150	1050	1050	650	60	3965	3890	1015	3265	1405	90	5155
B 1200 - 870	251	12	1150	1050	1050	650	60	3740	3665	1015	3040	1405	90	4480
B 1200 - 870	320	12	1150	1050	1050	650	60	3965	3890	1015	3265	1405	90	4850
B 1200 - 870	370	12	1150	1050	1050	650	60	3965	3890	1015	3265	1405	90	5110
B 1200 - 870	410	12	1150	1050	1050	650	60	3965	3890	1015	3265	1405	90	5290
A 1500-1060	340	14	1430	1300	1300	650	60	4000	3925	1475	3330	1860	90	5970
A 1600-1060	370	14	1540	1350	1300	760	70	4085	3995	1260	3375	1800	100	7050
A 1600-1060	410	14	1540	1350	1300	760	70	4085	3995	1260	3375	1800	100	7370
A 1600-1060	450	14	1540	1350	1300	775	70	4385	4295	1260	3675	1800	100	7790
A 1600-1060	500	14	1540	1350	1300	775	70	4385	4295	1260	3675	1800	100	8260
A 1600-1060	550	14	1540	1350	1300	775	70	4385	4295	1260	3675	1800	100	8480
B 1600-1060	410	14	1540	1350	1300	760	70	4085	3995	1260	3675	1800	100	7550
B 1600-1060	450	14	1540	1350	1300	775	70	4385	4295	1260	3675	1800	100	8170
B 1600-1060	500	14	1540	1350	1300	775	70	4385	4295	1260	3675	1800	100	8440
B 1600-1060	550	14	1540	1350	1300	775	70	4385	4295	1260	3675	1800	100	8660

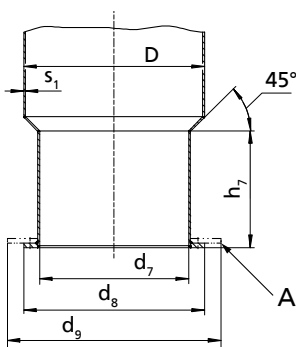

Dimensions of the discharge tube

A	Suction umbrella; option for reducing the minimum water level
---	---

Dimensions of the discharge tube [mm]

Size	Motor size	Poles	D	d <sub>7</sub>	d <sub>8</sub>	d <sub>9</sub>	h <sub>7</sub>	s <sub>1</sub>
A 700 - 470	80	6	711	600	710	1100	420	8
A 700 - 470	100	6	711	600	710	1100	420	8
A 700 - 470	120	6	711	600	710	1100	420	8
A 700 - 470	30	8	711	600	710	1100	420	8
A 700 - 470	40	8	711	600	710	1100	420	8
A 700 - 470	55	8	711	600	710	1100	420	8
A 700 - 470	70	8	711	600	710	1100	420	8
B 700 - 470	100	6	711	600	710	1100	420	8
B 700 - 470	120	6	711	600	710	1100	420	8
B 700 - 470	40	8	711	600	710	1100	420	8
B 700 - 470	55	8	711	600	710	1100	420	8
B 700 - 470	70	8	711	600	710	1100	420	8
B 700 - 470	100	8	711	600	710	1100	420	8
A 800 - 540	55	8	813	680	810	1250	525	8
A 800 - 540	70	8	813	680	810	1250	525	8
A 800 - 540	100	8	813	680	810	1250	525	8
B 800 - 540	70	8	813	680	810	1250	525	8
B 800 - 540	100	8	813	680	810	1250	525	8
A 900 - 540	120	8	914	700	910	1250	515	8
A 900 - 540	40	10	914	700	910	1250	515	8
A 900 - 540	60	10	914	700	910	1250	515	8
A 900 - 540	90	10	914	700	910	1250	515	8
B 900 - 540	120	8	914	700	910	1250	515	8

<sup>46)</sup> Pump set with 10 m power cable (400 V) and 5 m support rope

Size	Motor size	Poles	D	d <sub>7</sub>	d <sub>8</sub>	d <sub>9</sub>	h <sub>7</sub>	s <sub>1</sub>
B 900 - 540	160	8	914	700	910	1250	515	8
A 1000 - 700	120	10	1016	880	1015	1600	765	10
A 1000 - 700	155	10	1016	880	1015	1600	765	10
A 1000 - 700	200	10	1016	880	1015	1600	765	10
A 1000 - 700	250	10	1016	880	1015	1600	765	10
B 1000 - 700	155	10	1016	880	1015	1600	765	10
B 1000 - 700	200	10	1016	880	1015	1600	765	10
B 1000 - 700	250	10	1016	880	1015	1600	765	10
A 1200 - 870	190	12	1220	1070	1220	2000	1000	12
A 1200 - 870	251	12	1220	1070	1220	2000	1000	12
A 1200 - 870	320	12	1220	1070	1220	2000	1000	12
A 1200 - 870	370	12	1220	1070	1220	2000	1000	12
A 1200 - 870	410	12	1220	1070	1220	2000	1000	12
B 1200 - 870	251	12	1220	1070	1220	2000	1000	12
B 1200 - 870	320	12	1220	1070	1220	2000	1000	12
B 1200 - 870	370	12	1220	1070	1220	2000	1000	12
B 1200 - 870	410	12	1220	1070	1220	2000	1000	12
A 1500-1060	340	14	1525	1330	1520	2450	1460	12
A 1600-1060	370	14	1625	1420	1620	2450	1230	12
A 1600-1060	410	14	1625	1420	1620	2450	1230	12
A 1600-1060	450	14	1625	1420	1620	2450	1230	12
A 1600-1060	500	14	1625	1420	1620	2450	1230	12
A 1600-1060	550	14	1625	1420	1620	2450	1230	12
B 1600-1060	410	14	1625	1420	1620	2450	1230	12
B 1600-1060	450	14	1625	1420	1620	2450	1230	12
B 1600-1060	500	14	1625	1420	1620	2450	1230	12
B 1600-1060	550	14	1625	1420	1620	2450	1230	12

**Types of installation**

Overview of installation types

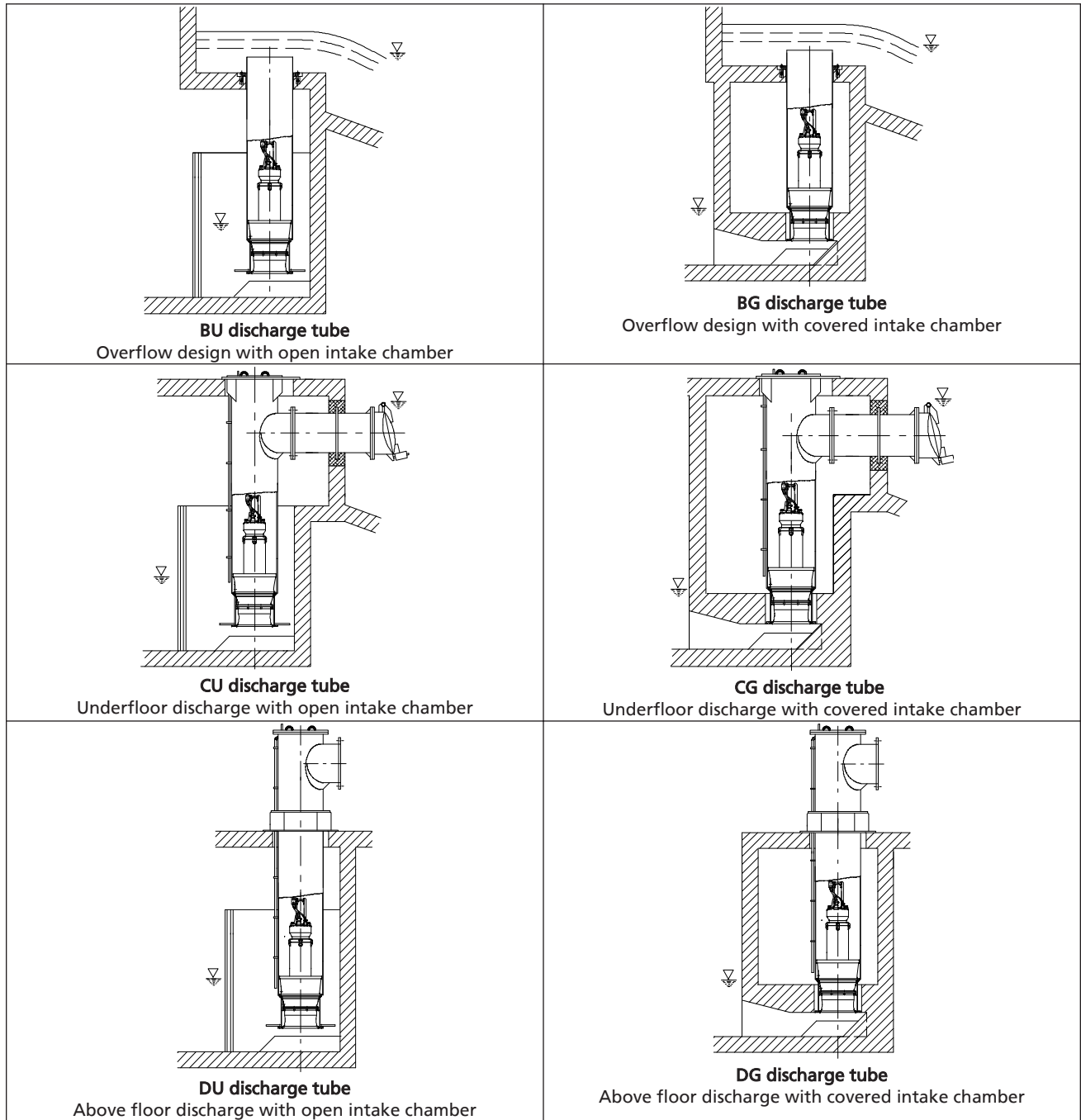

### Scope of supply

Depending on the model, the following items are included in the scope of supply:

- **Basic variant:** pump set complete with power cable 32.8 ft [10 m]
- O-ring
- Back-up name plate

#### **Accessories (optional):**

- Support rope
- Accessories for installing the cable support
  - Spacer
  - Turnbuckle
  - Support
  - Shackle
  - Cable clamps
- Cable support sleeves
- Flow-straightening vane to prevent floor vortices
- Discharge tube in various designs (steel or GFK)

## Accessories

### Flow-straightening vane and intake chamber

#### Design of the intake chamber wall surfaces (to prevent vortex formation)

The flow-straightening vane is indispensable for the inlet conditions of the pump set. It prevents the development of a submerged vortex (floor vortex) which could cause a drop in performance, for example. In addition, the floor and wall surfaces of the intake chamber should be designed as a rough concrete surface. Rough surfaces minimize the separation of boundary layers that may cause wall and floor vortices.

### Flow-straightening vane and intake chamber

- The anti-vortex vanes in the bellmouth must be aligned with the flow-straightening vane.
- The bail of the pump is oriented in the same direction as the anti-vortex vanes in the bellmouth.

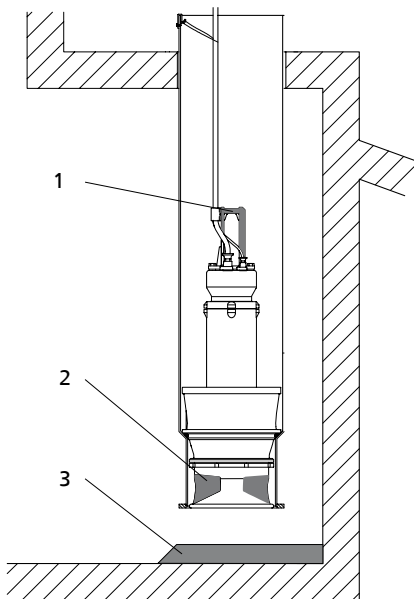

Installation position of the pump set

1	Bail
2	Anti-vortex vanes
3	Flow-straightening vane

Variant 1  
 Flow-straightening vane cast from concrete

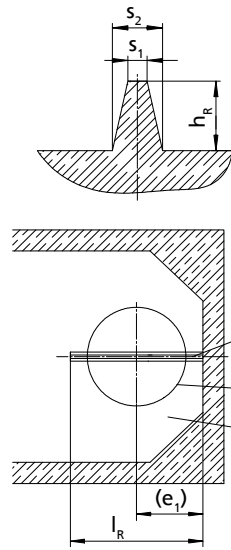

Variant 2  
 Steel section

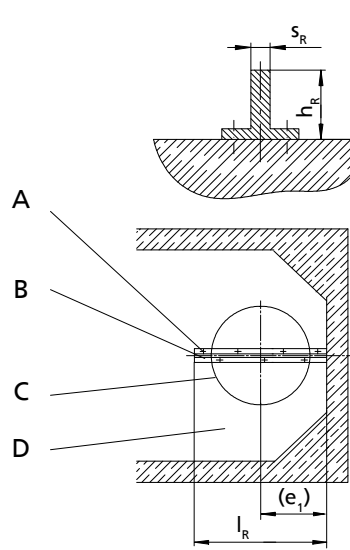

A	Bolted to the floor of the intake chamber
B	Flow-straightening vane centered beneath the discharge tube
C	Discharge tube
D	Intake chamber



**Support rope and turnbuckle in the discharge tube**

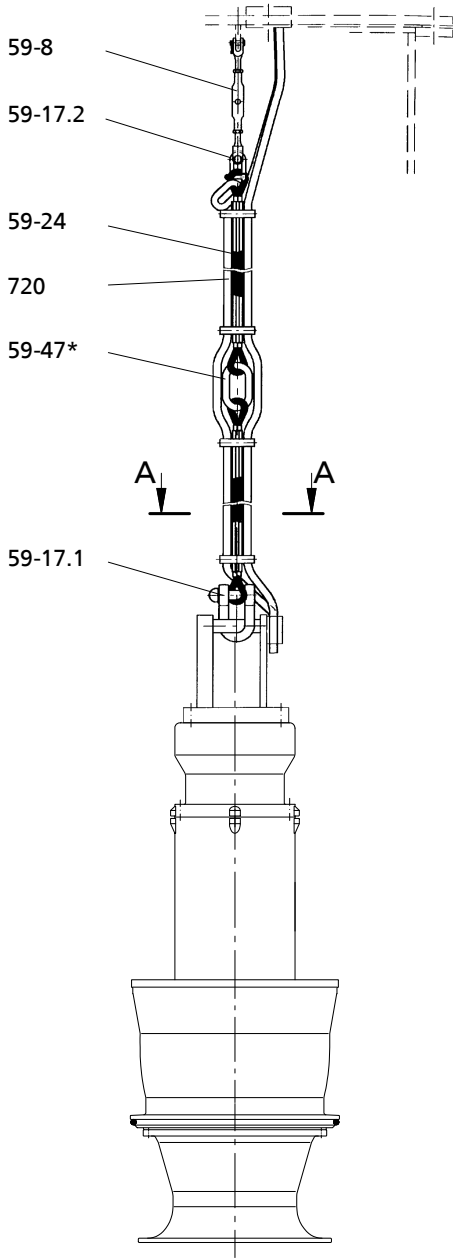

For large installation depths  
 (with support spacer)

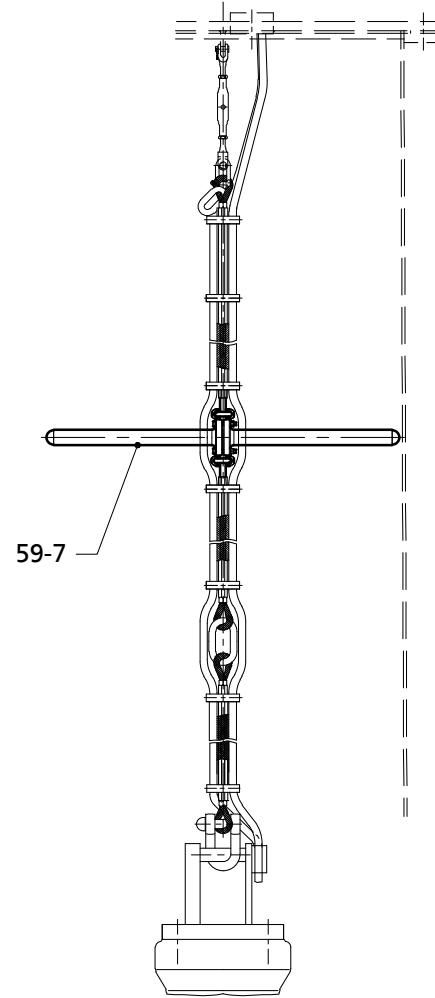

\*= The number of (intermediate) lifting rings depends on the lifting height of the lifting equipment and on the building structure. (Intermediate lifting rings are supplied as an option).

List of components

Part no.	Description	Material
59-8	Turnbuckle	Stainless steel
59-17.2	Shackle	Stainless steel
59-47	(Intermediate) lifting ring(s)	Stainless steel
59-24	Rope, low rotation design	Stainless steel
720	Spacer	EPDM
59-17.1	Shackle	Galvanized steel (stainless steel optional)
59-7	Support spacer	GFRP

Cross-section of cable support

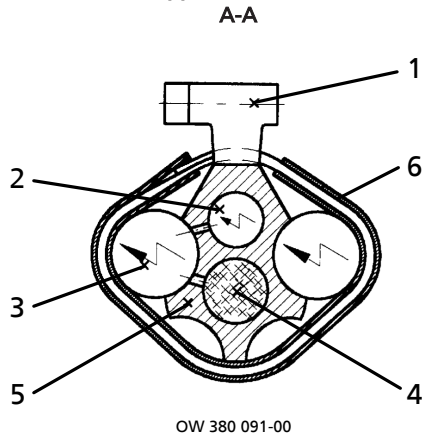

List of components

Part no.	Description	Part no.	Description
1	Cable clamp (approximately every 400 mm)	4	Support rope 59-24
2	Control cable	5	Spacer
3	Power cable	6	Clamp cover

Discharge tube cover with cable gland

Design: with welding sleeve

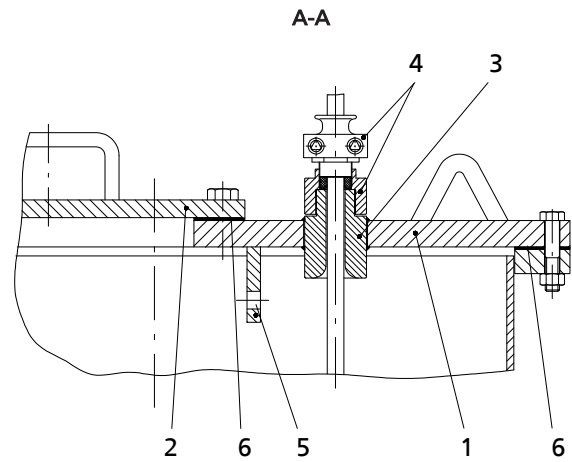
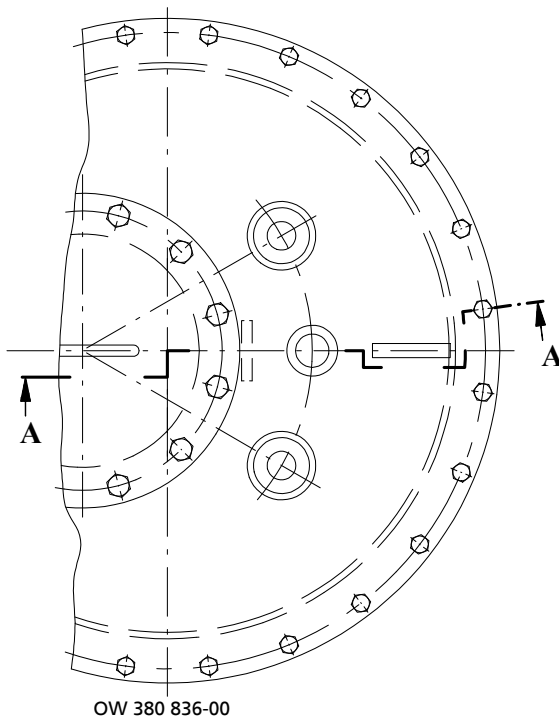

List of components

Part no.	Description
1	Discharge tube cover <sup>47)</sup>
2	Cover
3	Welding sleeve
4	Threaded bush with cable entry to DIN 22419 with strain relief and protection against kinking and twisting
5	Eyeplate for fastening the cable support (support rope)
6	Gasket (e.g. rubber with fabric reinforcement)

Design variant: with transit frame (up to 1 bar)

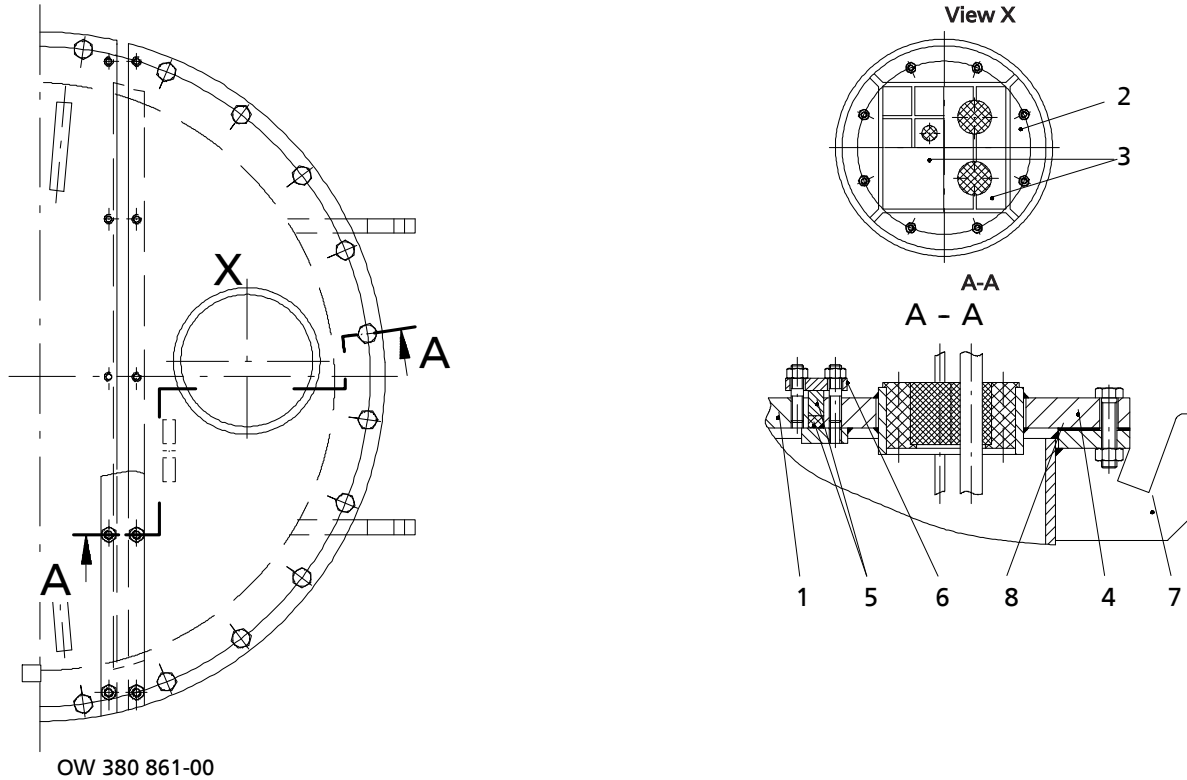

List of components

Part no.	Description
1	Discharge tube cover <sup>48)</sup>
2	Transit frame (cable gland)
3	Packing and insert blocks
4	Cover segment with cable gland
5	Sealing of split cover with closed cell profile gasket
6	Gap cover
7	Support brackets for cover segment with cable glands
8	Gasket (e.g. rubber with fabric reinforcement)

<sup>47)</sup> Discharge tube cover also available in split design.

<sup>48)</sup> Discharge tube cover also available in single-piece design.

General assembly drawings

Amacan P 500-270

Amacan P 600-350

Motor version: UAG

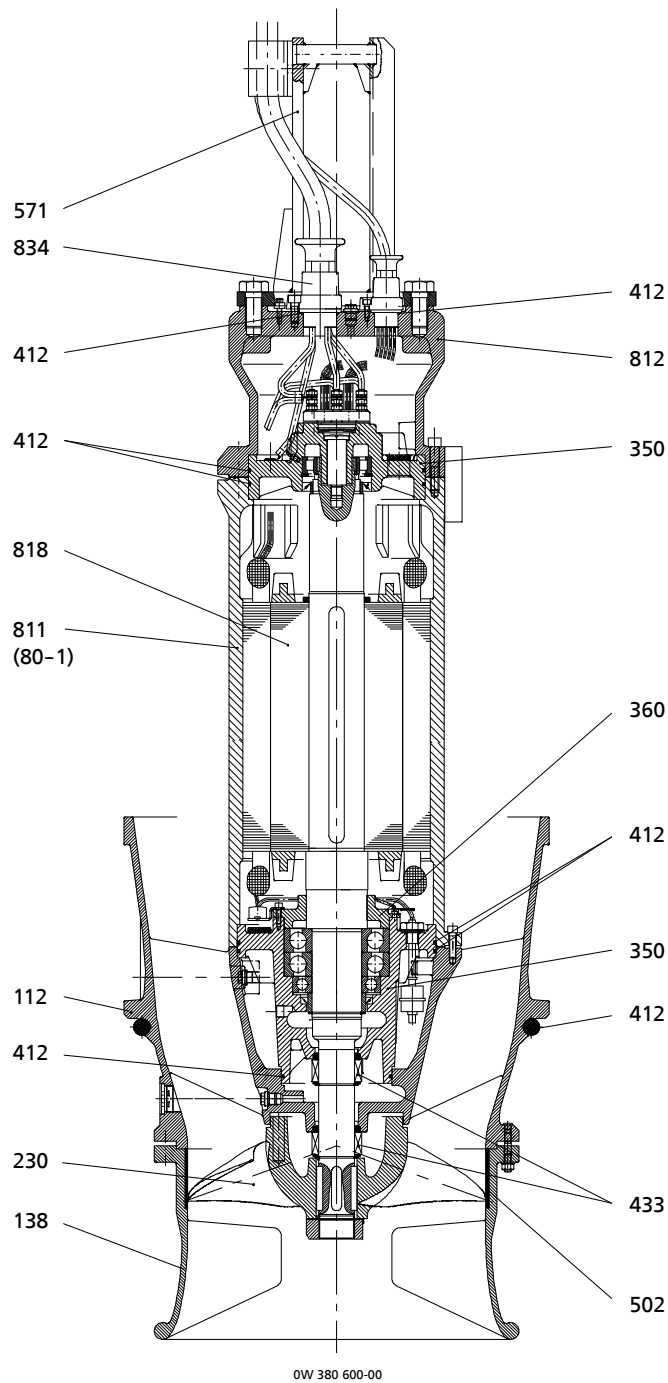

List of components

Part no.	Description	Part no.	Description
112	Pump bowl	502	Casing wear ring
138	Bellmouth	571	Bail
230	Impeller	811	Motor housing
350	Bearing housing	812	Motor housing cover
360	Bearing cover	818	Shaft (rotor)
412	O-ring	834	Cable gland
433	Mechanical seal	-	-

Amacan P 700-470  
 Amacan P 800-540  
 Amacan P 900-540  
 Amacan P 1000-700  
 Amacan P 1200-870  
 Amacan P 1500-1060  
 Amacan P 1600-1060  
 Motor version: UTG/XTG

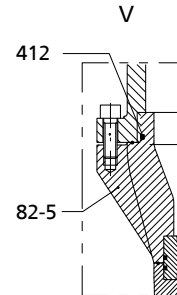
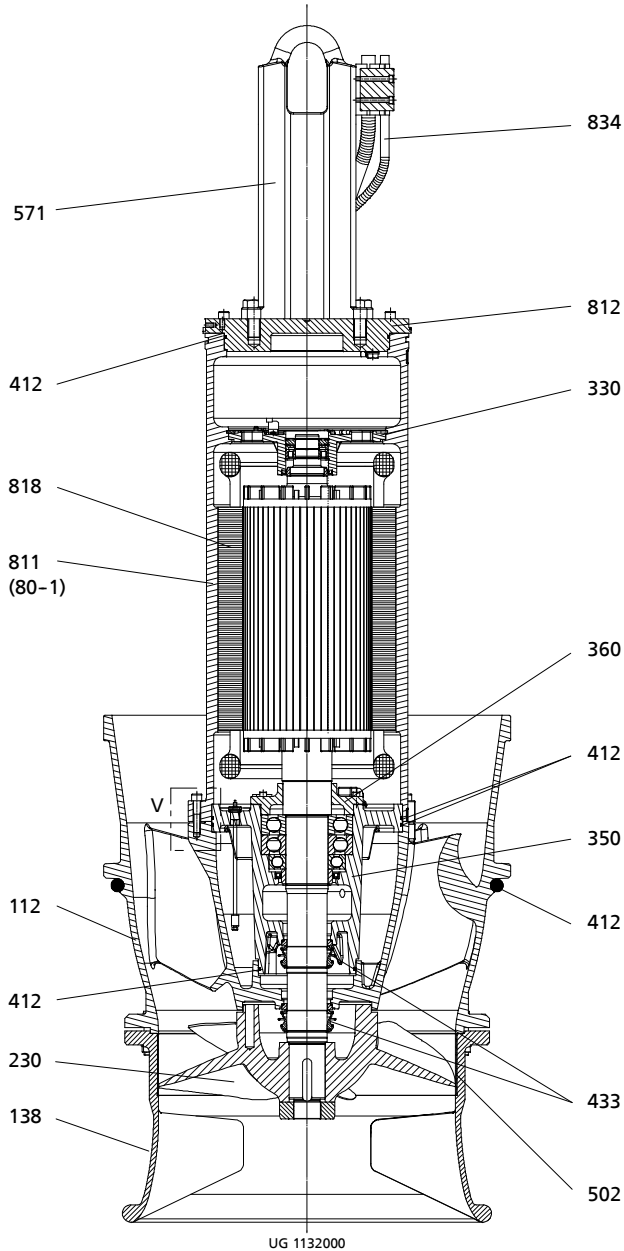

UG 1132000

List of components

Part no.	Description	Part no.	Description
112	Pump bowl	502	Casing wear ring
138	Bellmouth	571	Bail
230	Impeller	811	Motor housing
330	Bearing bracket	812	Motor housing cover
350	Bearing housing	82-5	Adapter
360	Bearing cover	818	Shaft (rotor)
412	O-ring	834	Cable gland
433	Mechanical seal	-	-



**KSB Aktiengesellschaft**

P.O. Box 200743 • 06008 Halle (Saale) • Turmstraße 92 • 06110 Halle (Germany)

Tel. +49 345 4826-0 • Fax +49 345 4826-4699

[www.ksb.com](http://www.ksb.com)

04.07.2013

1580.56/04-US